

Arrangement

The Model 7000 Gyro System consists of the Gyro unit, Motor Drive Box, Gyro Control Box, Cooling Loop Components, Keypad, Display, and Cables (AC and DC power cables and CANbus cable not included).

Installation Location

The Gyro is a torque device and does not have to be installed in a specific hull location or on the centerline. However, the Gyro should not be installed at forward locations in a high speed boat where the vertical accelerations exceed ± 1 G. The Gyro Control Box must be mounted on a transverse bulkhead, frame or subframe.

Mounting Dimensions

See dimension diagrams on previous page.

Loads

The installer is responsible for designing the foundation to which the Gyro's saddle beams are attached and for ensuring that this foundation can safely transfer the concentrated Gyro loads from the saddle beams to the adjacent hull structure. Loads that the Gyro imposes on the saddle beams are explained on Seakeeper Drawing 10310.

Cooling

The Gyro bearings and Motor Drive Box are cooled by a closed glycol cooling loop that incorporates a sea water heat exchanger. The installer is responsible for providing 8 lpm (2.1 gpm) raw water at ambient sea temperature and 6.9 Bar maximum pressure to the heat exchanger. The ambient air temperature in the compartment in which the Gyro Control and Motor Drive Boxes are mounted should not exceed 50° C.

Electrical

The installer is responsible for supplying 185-230 VAC, 50/60 Hz, single phase power on a 30A service to the Motor Drive Box and either 12 VDC @ 20A or 24 VDC @ 10A service to the Gyro Control Box. The DC supply voltage for the Gyro Control Box must be specified at order.

Operator Controls

A Keypad and small Display are provided to start, operate, monitor, and shutdown the Gyro.

Performance

Gyro reduction of boat roll is a function of the boat's displacement, transverse metacentric height (GMT) and hull damping as well as the operating conditions (speed and heading with respect to waves) and sea state. The Gyro controller regulates the active hydraulic brake to ensure the Gyro's anti-roll torque is maximized irrespective of hull characteristics or operating conditions. In heavy seas, the Gyro rpm may droop when the required power exceeds 2000 watts – this is normal and is designed to limit large power demands at the expense of a small loss of performance

Alarm and Monitoring

Sensors, alarms and shutdowns are provided to allow unattended operation. Sensors measure flywheel bearing temperatures, motor and drive temperatures, vacuum pressure, gimbal angle, brake pressure, and ship motion. The Gyro controller sends sensor values and alarm information to the display and also locks the brake and shuts down the motor drive in the event of a fault or alarm condition. Gyro operating history during faults or alarms is recorded in the controller's memory for subsequent recall by a qualified service person if needed.

Safety

The brake automatically locks the Gyro so it cannot generate excessive anti-rolling torque loads in the event of a system fault or alarm, loss of electrical power or loss of brake pressure. The brake can also be locked from the Keypad or by shutting off power locally at the Motor Drive Box or Gyro Control Box.



PO Box 999
14528 South Solomons Island Road
Solomons, MD 20688 USA
Phone: 410.326.1590
Fax: 410.326.1199
Website: www.seakeeper.com



INNOVATIVE STABILIZATION TECHNOLOGY

SEAKEEPER™ GYRO STABILIZATION SYSTEM
VIRTUALLY ELIMINATE ZERO AND LOW SPEED BOAT ROLL,
THE WORST PART OF BEING ON A BOAT

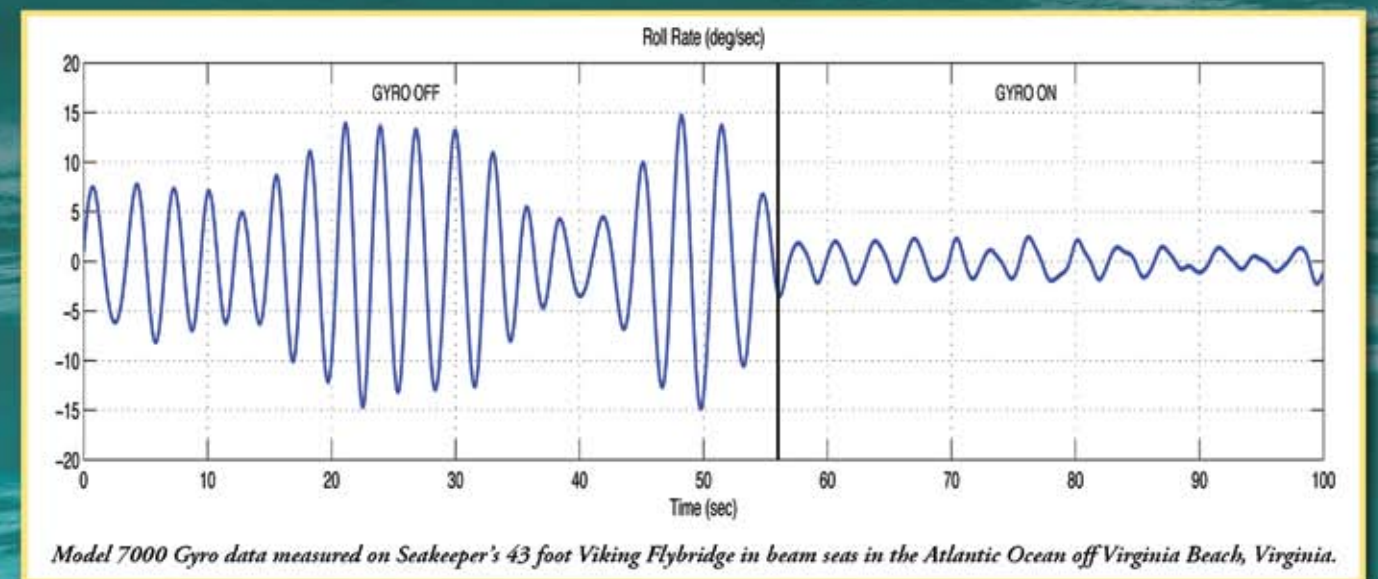

UNRIVALED ROLL REDUCTION

- Innovative Gyro technology virtually eliminates zero and low speed roll
- Speed Independent – works equally well at anchor or underway
- Simple installation
- Suitable for planing boats with no drag producing protrusions from the hull
- Low power consumption and low weight

Seakeeper Gyro

“Rocking the boat” is an expression for upsetting things for good reason. Boat roll is the most disorienting contrast with dry land experience and the least desirable motion on a boat leaving aside sinking. Uncomfortable, tiring, and probably the greatest cause of seasickness it has, until now, been an unavoidable price to pay for the pleasure of being on the water.

With advent of the Seakeeper Gyro, that is changed forever. Using a device known as a “Control Moment Gyro” and employing the magical principles of gyro-dynamics, it exerts a powerful righting force that virtually eliminates boat roll without any need for drag-producing protrusions from the boat hull. Like the control moment gyros used to position spacecraft, it has a flywheel that spins in a near vacuum, thus virtually eliminating air friction, making for low power consumption and weight. Controlled by state of the art motion sensors and computer

processors, it is one of the more astonishing uses of technology to improve human comfort.

The Seakeeper Model 7000 Gyro is designed for boats up to approximately 55’ in length for single unit installations and for larger boats when fitted with multiple units.

Seakeeper Gyro technology offers numerous advantages over fin-based roll stabilization systems. Fin systems are speed dependent always balancing fin size with projected cruising speed to create minimum drag for desired performance. The result is that at zero speed they have no effect and at less than cruising speed performance drops off sharply. In contrast, the Seakeeper Gyro remains fully effective from zero speed right through planing speeds, including the roughest conditions when the boat has to slow down. Because the gyro requires no protrusions from the hull, it is not subject to snagging seaweed and flotsam or to damage from grounding.

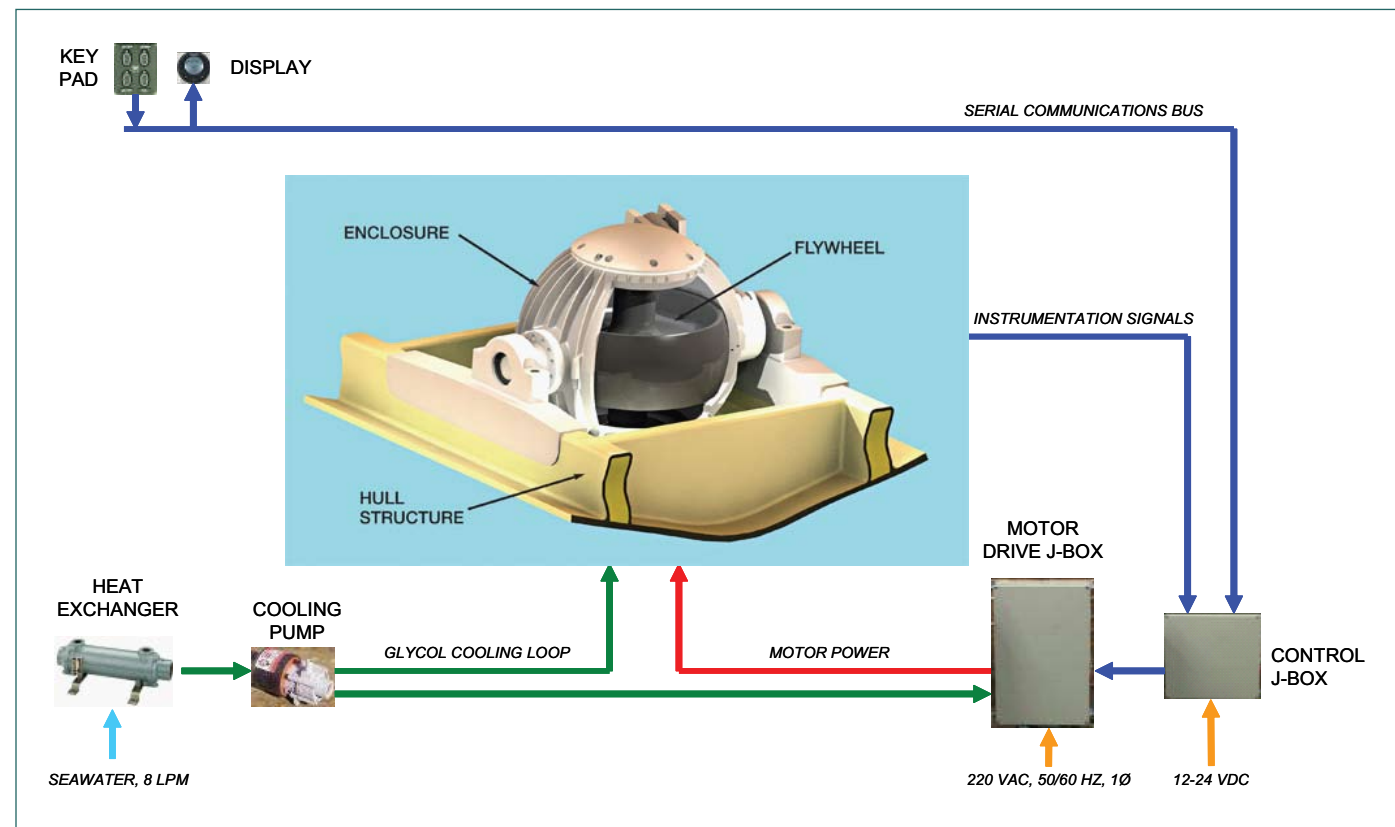

Model 7000 Gyro Specification

Rated RPM	10,000 RPM
Angular Momentum at Rated RPM	7,000 N-M-S
Anti-Rolling Torque at Rated RPM	15,000 N-M
Spool-up Time to Rated RPM	45 Minutes
Spool-up Time to Stabilization (70% Rated RPM)	25 Minutes
Spool-up Power	
AC Motor	3000 Watts
DC Control	240 Watts
Operating Power	
AC Motor (sea state dependent)	1500-2000 Watts
DC Control	240 Watts
AC Input Voltage	185-230 VAC, 50/60 Hz, Single Phase
DC Input Voltage	12 VDC @ 20 Amps or 24 VDC @ 10 Amps
Ambient Sea Water Supply to Gyro Heat Exchanger	8 liters/min (2.1 gal/min)
Maximum Ambient Air Temperature	50 Deg C (122 Deg F)
Weight	450 Kg (990 Lbs)

Envelope Dimensions

Gyro Assembly

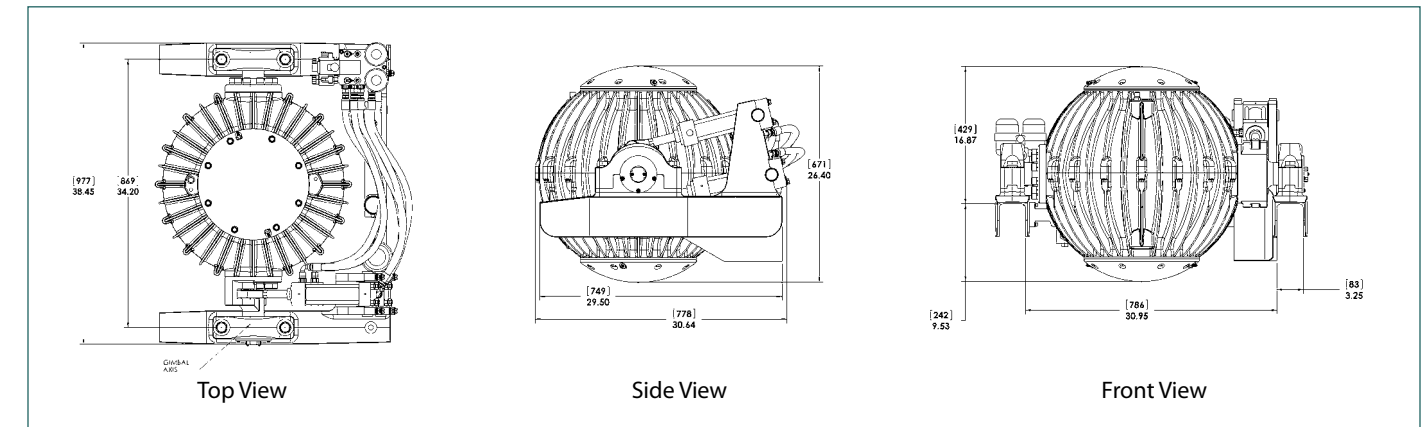

Controls

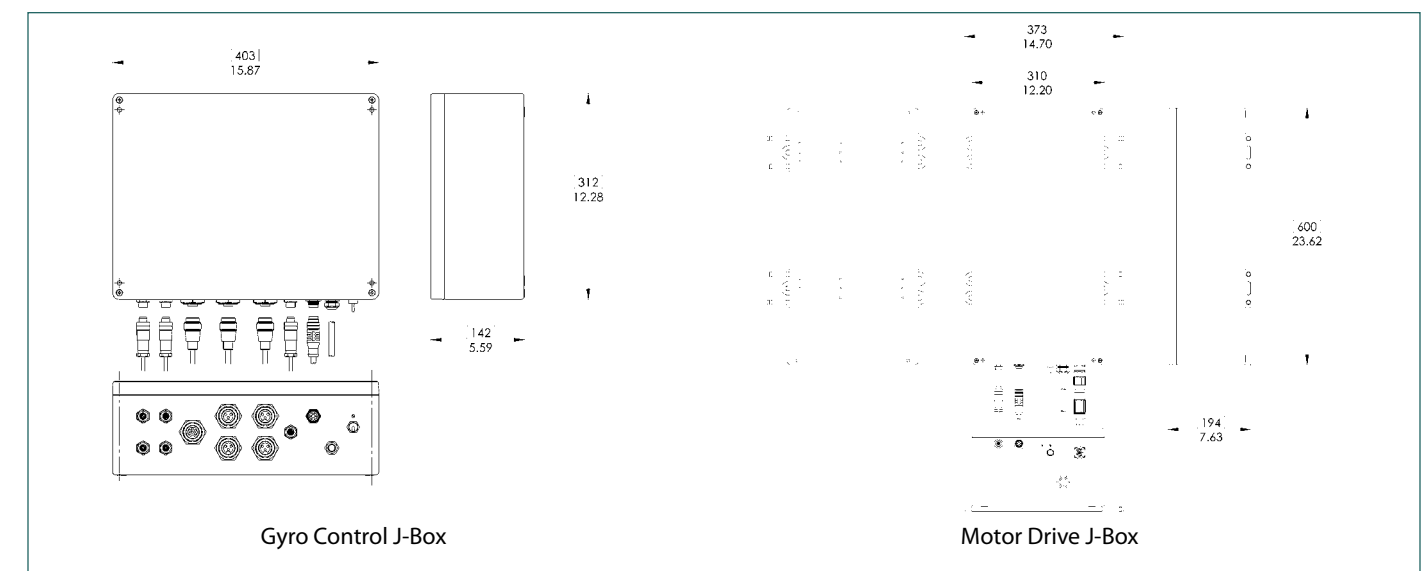

Specifications subject to change without notice.