

- NOTES:
- 1) THE FIXTURE MUST BE USED TO CHECK FIT AND SPACING OF SADDLES RELATIVE TO HULL STRUCTURE AS WELL AS LOCATE SADDLES ACCURATELY DURING THE BONDING PROCESS.
 - 2) SADDLE IS COMPLETELY SYMMETRICAL AND CAN BE USED IN ANY OF THE FOUR LOCATIONS. SADDLE IS PROVIDED SEPARATELY IN P/N 90085, SADDLE KIT, ALONG WITH M16 FASTENER SET.
 - 3) THE GYRO'S FOUNDATION EXTENDS BEYOND THE PLAN DIMENSIONS OF THIS FIXTURE. IT IS IMPORTANT THAT THE BUILDER / DESIGNER / INSTALLER IS FAMILIAR WITH SEAKEEPER DRAWING 90067 - M21000 INSTALLATION DETAILS. THIS DRAWING SHOWS RELATIONSHIP BETWEEN SADDLE DIMENSIONS AND OVERALL FOUNDATION DIMENSIONS.

REVISIONS					
REV.	ECN NO.	ZONE	DESCRIPTION	DATE	APPROVED
2	ECN0032		1. ADDED ITEM 12 TO BOM.	04NOV10	BHS BRD

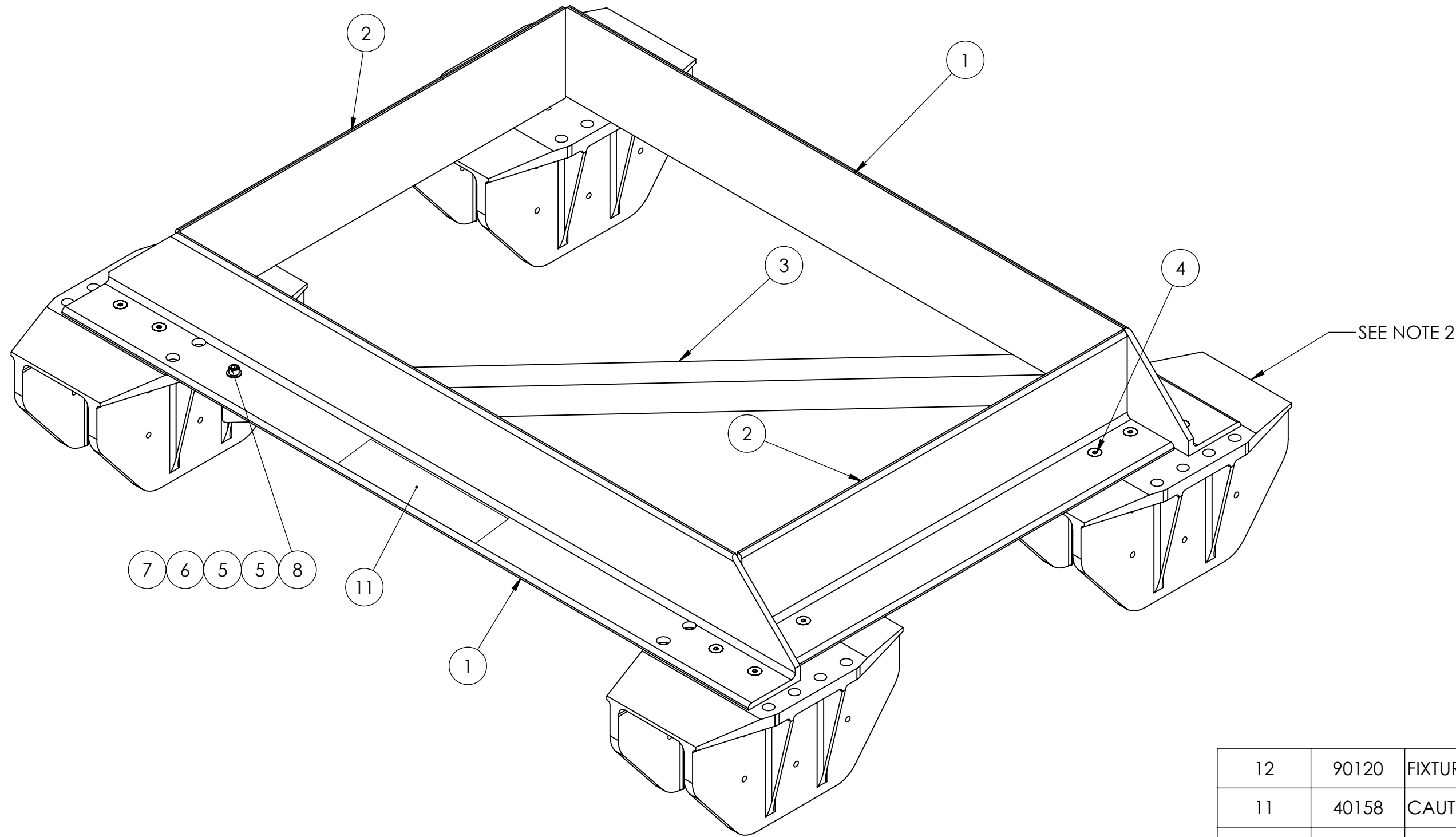

ITEM NO.	PartNo	DESCRIPTION	QTY	NOTE
12	90120	FIXTURE MANUAL	1	
11	40158	CAUTION LABEL	1	
10	40192	Hex Key Wrench, 7/32	1	
9	40191	Hex Key Wrench, 5/16	1	
8	60126	Skt Hd Cap Screw, 3/8-16 x 1.50 Lg, Alloy Steel	2	
7	60125	Hex Nut, 3/8-16, Zinc Plated Steel	2	
6	60151	Spring Lock Washer, 3/8 18-8 SS	2	
5	60150	Flat Washer, 3/8 18-8 SS	4	
4	60122	Flat Skt Head Cap Screw, 3/8-16 x .75 Long, Alloy Steel	16	
3	10515	Installation Jig Angle - Diagonal	1	
2	10514	Installation Jig Angle - Short	2	
1	10513	Installation Jig Angle - Long	2	

THIRD ANGLE PROJECTION

PROPRIETARY AND CONFIDENTIAL

THE INFORMATION CONTAINED IN THIS DRAWING IS THE SOLE PROPERTY OF SEAKEEPER, INC. ANY REPRODUCTION IN PART OR AS A WHOLE WITHOUT THE WRITTEN PERMISSION OF SEAKEEPER, INC. IS PROHIBITED.

UNLESS OTHERWISE SPECIFIED:
DIMENSIONS ARE IN INCHES
TOLERANCES:
-TWO PLACE DECIMAL ±0.01
-THREE PLACE DECIMAL ±.005
-ALL DIAMETERS RUNOUT TO DATUM SURFACES .005 MAX
-ALL FACES PERPENDICULAR TO DATUM SURFACES .005 MAX
-ALL EDGE BREAKS .010-.020 X 45°
-ALL FILLET RADI .010-.020
-SURFACE FINISH

DO NOT SCALE DRAWING

NAME	DATE
DRAWN BHS	07APR10
CHECKED BRD	08APR10
QTY APPR.	
ENG APPR. JDA	12APR10

COMMENTS:

P.O. BOX 999
SOLOMONS, MARYLAND 20688, USA
PHONE: (410) 326-1590 FAX: (410) 326-1199

SEAKEEPER™

**TITLE: MODEL 21000 GYRO SADDLE
INSTALLATION FIXTURE KIT**

SIZE C	DWG. NO. 90088	REV 2
---------------	-----------------------	--------------

SCALE: 1:10 WEIGHT: 155.12 SHEET 1 OF 2

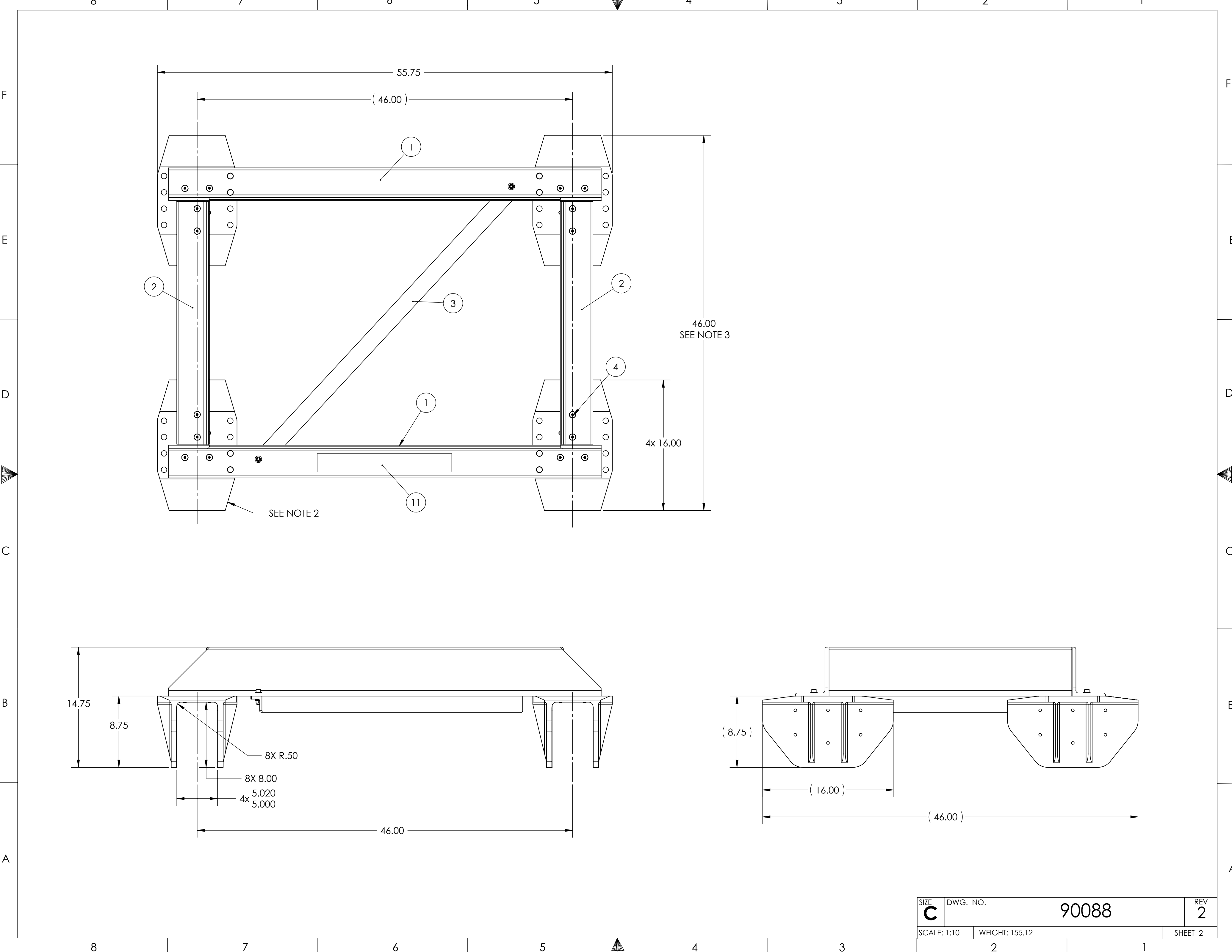

SEE NOTE 2

46.00
SEE NOTE 3

4x 16.00

8X R.50

8X 8.00

4x 5.020
5.000

SIZE C	DWG. NO. 90088	REV 2
SCALE: 1:10	WEIGHT: 155.12	SHEET 2