

NOTES:

1. CABLES PROVIDED TO CONNECT THE MOTOR DRIVE BOX (ITEM 2) TO INPUT AND OUTPUT POWER ARE SUPPLIED AS LENGTH 3m. THE LOCATIONS CHOSEN FOR POWER DISTRIBUTION SHOULD TAKE THIS INTO CONSIDERATION.

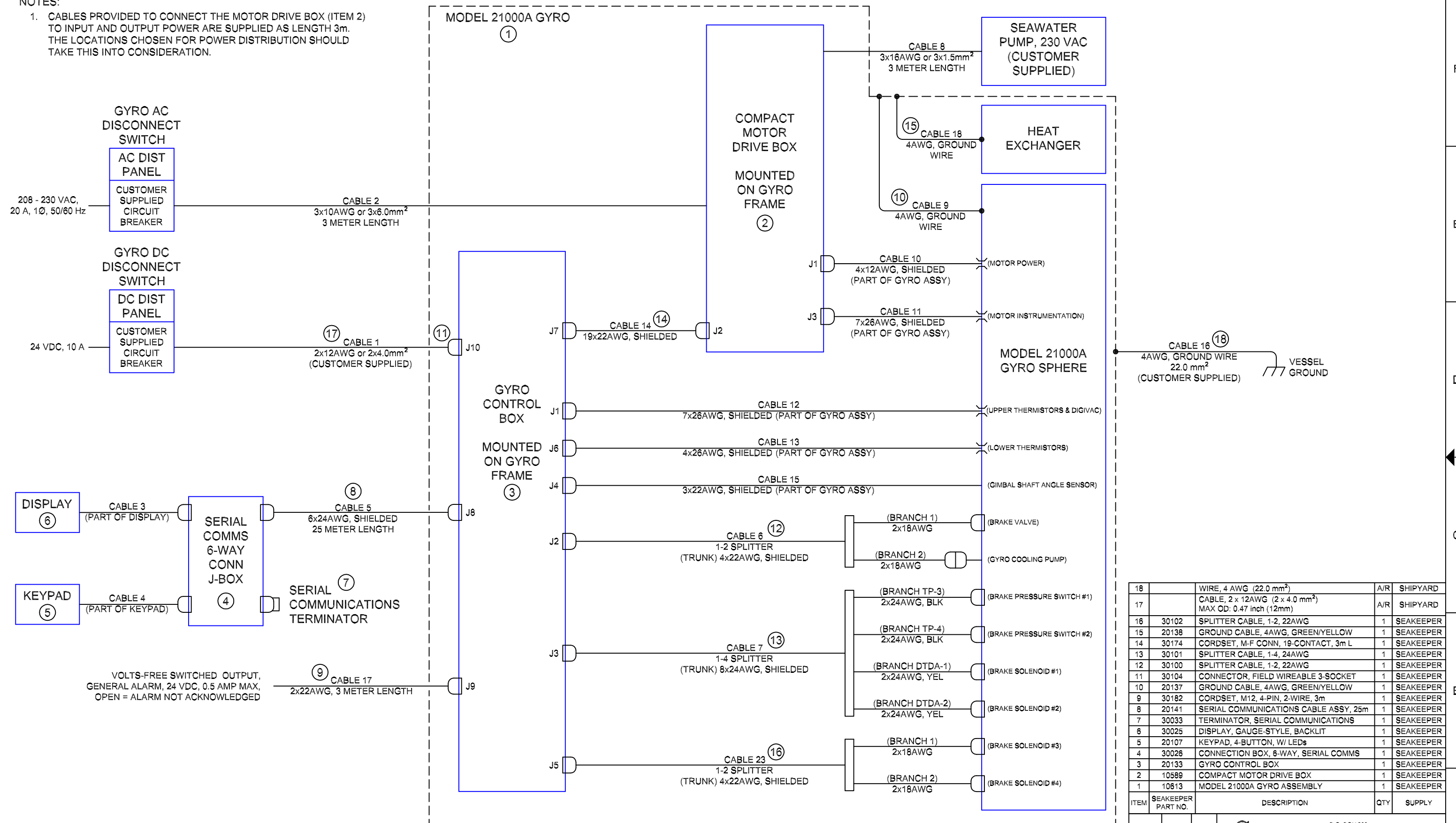

ITEM	SEAKEEPER PART NO.	DESCRIPTION	QTY	SUPPLY
18		WIRE, 4 AWG (22.0 mm ²)	A/R	SHIPYARD
17		CABLE, 2 x 12AWG (2 x 4.0 mm ²) MAX OD: 0.47 inch (12mm)	A/R	SHIPYARD
16	30102	SPLITTER CABLE, 1-2, 22AWG	1	SEAKEEPER
15	20138	GROUND CABLE, 4AWG, GREEN/YELLOW	1	SEAKEEPER
14	30174	CORDSET, M-F CONN, 19-CONTACT, 3m L	1	SEAKEEPER
13	30101	SPLITTER CABLE, 1-4, 24AWG	1	SEAKEEPER
12	30100	SPLITTER CABLE, 1-2, 22AWG	1	SEAKEEPER
11	30104	CONNECTOR, FIELD WIREABLE 3-SOCKET	1	SEAKEEPER
10	20137	GROUND CABLE, 4AWG, GREEN/YELLOW	1	SEAKEEPER
9	30182	CORDSET, M12, 4-PIN, 2-WIRE, 3m	1	SEAKEEPER
8	20141	SERIAL COMMUNICATIONS CABLE ASSY, 25m	1	SEAKEEPER
7	30033	TERMINATOR, SERIAL COMMUNICATIONS	1	SEAKEEPER
6	30025	DISPLAY, GAUGE-STYLE, BACKLIT	1	SEAKEEPER
5	20107	KEYPAD, 4-BUTTON, W/ LEDs	1	SEAKEEPER
4	30026	CONNECTION BOX, 6-WAY, SERIAL COMMS	1	SEAKEEPER
3	20133	GYRO CONTROL BOX	1	SEAKEEPER
2	10589	COMPACT MOTOR DRIVE BOX	1	SEAKEEPER
1	10613	MODEL 21000A GYRO ASSEMBLY	1	SEAKEEPER

NAME	DATE	TITLE
DRAWN S. GOSS	21MAR11	MODEL 21000A GYRO CABLE BLOCK DIAGRAM
CHECKED H. SEBRA	04APR11	
ENG APPR. B.DOUTRICH	26APR11	
COMMENTS:		

SIZE D	DWG NO. 90152	REV 1
SCALE N/A	WEIGHT N/A	SHEET 1 OF 1

THE INFORMATION CONTAINED IN THIS DRAWING IS THE SOLE PROPERTY OF SEAKEEPER, INC. ANY REPRODUCTION IN PART OR AS A WHOLE WITHOUT THE WRITTEN PERMISSION OF SEAKEEPER, INC. IS PROHIBITED.

LAST CABLE NO: 23
CABLE NOS. NOT USED: 19-22