

NOTES:

- 1) SEE SEAKEEPER MODEL 7000A GYRO INSTALLATION MANUAL FOR TECHNICAL DETAILS.
- 2) MOTOR DRIVE BOX AND ASSOCIATED CABLES NOT SHOWN FOR CLARITY.
- 3) SEE REFERENCES 1 THROUGH 6 FOR RELATED ELECTRICAL / ELECTRONICS AND COOLING CIRCUIT DRAWINGS.
- 4) GYRO ASSEMBLY WEIGHT = 445 kg (982 lbs.)
- 5) RAW WATER COOLING REQUIREMENT IS 2 GPM (8 LITRES/MIN) OR GREATER CONTINUOUS FLOW. PROVIDED CONNECTIONS ARE 1/2" HOSE BARB. USE OF RAW WATER STRAINER IS REQUIRED.
- 6) TWO LIFTING EYES ARE PROVIDED ON THE TOP OF THE GYRO FOR USE WITH A CHAIN/SPREADER BAR (SEE SHEET 3). THE OFFSET CENTER OF GRAVITY LOCATION WILL REQUIRE A STABILIZING LINE BE ATTACHED BETWEEN THE SPREADER BAR AND THE TOP CYLINDER TRUNNION TO LEVEL THE GYRO.
- 7) IT IS RECOMMENDED THAT A SAFETY ENCLOSURE BE INSTALLED AROUND GYRO ASSEMBLY TO PREVENT PERSONNEL OR EQUIPMENT ENTANGLEMENT WHILE GYRO IS IN OPERATION. IF THE ENCLOSURE WILL ALSO SERVE TO DAMPEN SOUND BEING EMITTED FROM GYRO, A CIRCULATION/ EXCHANGE FAN IS RECOMMENDED TO MAINTAIN AIR INSIDE SOUND ENCLOSURE AT SAME TEMPERATURE AS COMPARTMENT IN WHICH GYRO IS INSTALLED.

REVISIONS				
REV.	ECN NO.	DESCRIPTION	DATE	APPROVED
2		1. ADDED SADDLE BOND AREAS ON SHEET 5. 2. UPDATED VIEWS SHOWING GROUND CABLE ATTACHMENT POINT TO ENCLOSURE.	14SEPT09	BRD
3	ECN0021	UPDATED VIEWS FOR HEAT EXCHANGER WITH INTEGRAL HOSE BIBS.	27AUG10	BHS, BRD

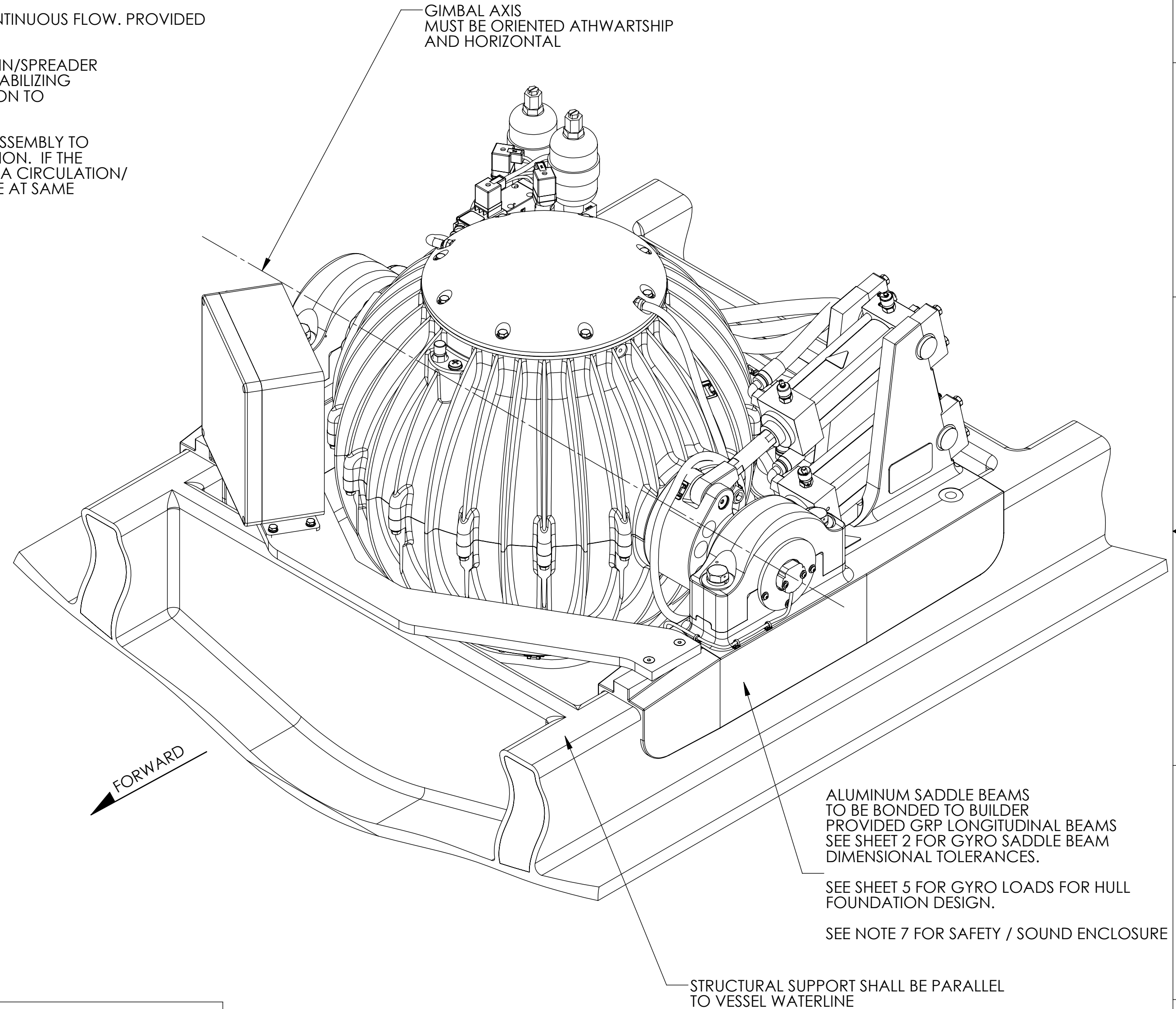

6	90009	MODEL 7000 GYRO OPERATOR DISPLAY ENVELOPE & MOUNTING DETAILS
5	90035	MODEL 7000A GYRO OPERATOR KEYPAD ENVELOPE & MOUNTING DETAILS
4	90010	MODEL 7000 GYRO SERIAL COMMS CONNECTION BOX ENVELOPE & MOUNTING DETAILS
3	90007	MODEL 7000 GYRO MOTOR DRIVE J-BOX ENVELOPE & MOUNTING DETAILS
2	90023	MODEL 7000A GYRO CABLE BLOCK DIAGRAM
1	90003	MODEL 7000 GYRO COOLING WATER SCHEMATIC
REF	DWG NO.	TITLE

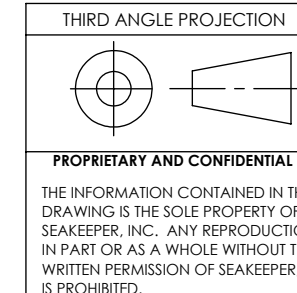

**PROPRIETARY AND CONFIDENTIAL**  
 THE INFORMATION CONTAINED IN THIS DRAWING IS THE SOLE PROPERTY OF SEAKEEPER, INC. ANY REPRODUCTION IN PART OR AS A WHOLE WITHOUT THE WRITTEN PERMISSION OF SEAKEEPER, INC. IS PROHIBITED.

UNLESS OTHERWISE SPECIFIED: DIMENSIONS ARE IN MILLIMETERS TOLERANCES: -TWO PLACE DECIMAL -THREE PLACE DECIMAL -ALL DIAMETERS RUNOUT TO DATUM SURFACES -ALL FACES PERPENDICULAR TO DATUM SURFACES -ALL EDGE BREAKS -ALL FILLET RADII -SURFACE FINISH		NAME	DATE
DRAWN		BRD	07AUG09
CHECKED		BHS	07AUG09
ENG APPR.		JDA	18SEPT09
COMMENTS:			
DO NOT SCALE DRAWING			

**SEAKEEPER**  
 P.O. BOX 999  
 SOLOMONS, MARYLAND 20688, USA  
 PHONE: (410) 326-1590 FAX: (410) 326-1199

TITLE: **MODEL 7000A GYRO INSTALLATION DETAILS**

SIZE: **C** DWG. NO. **90031** REV **3**

SCALE: WEIGHT: SHEET 1 OF 5

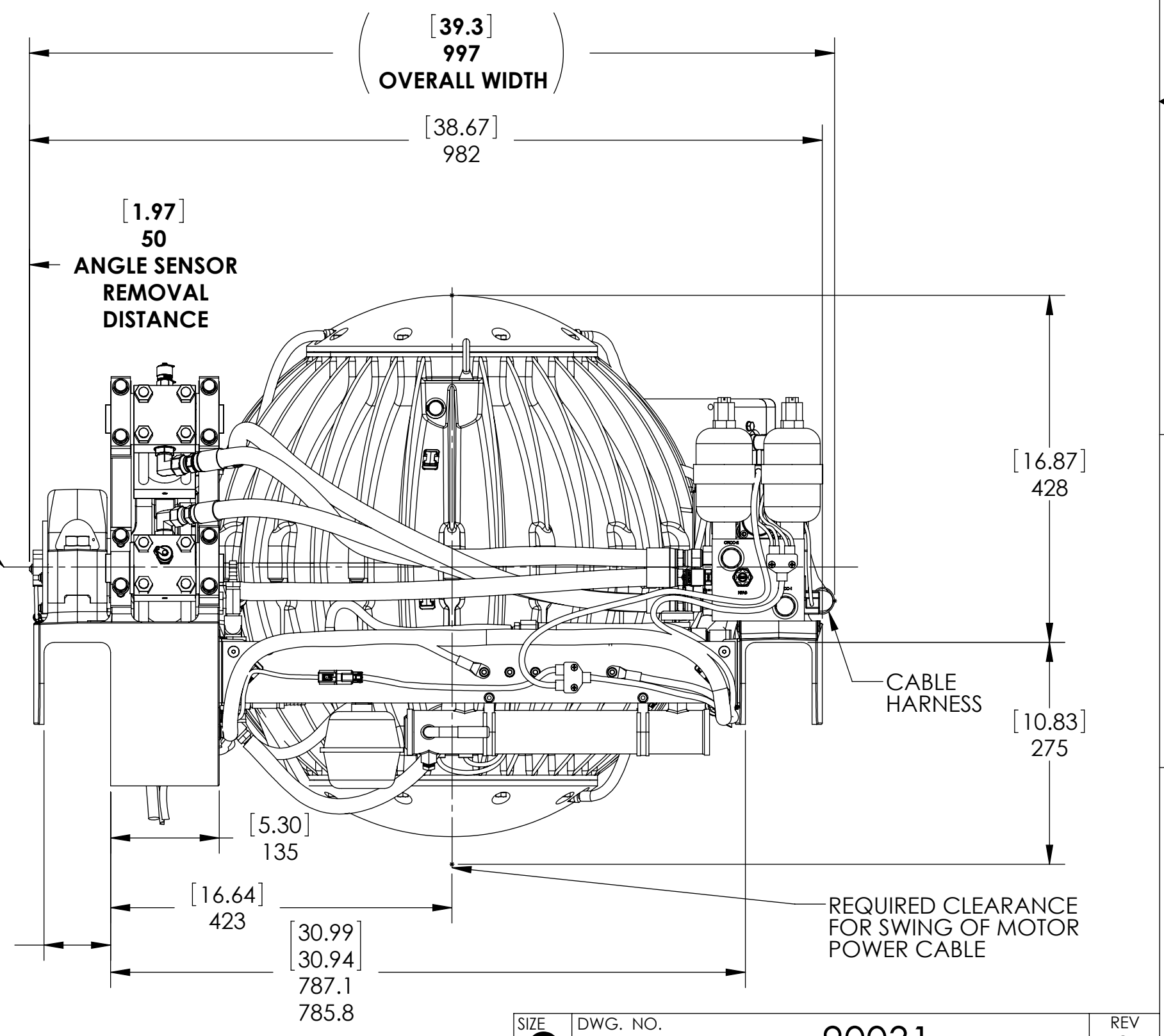
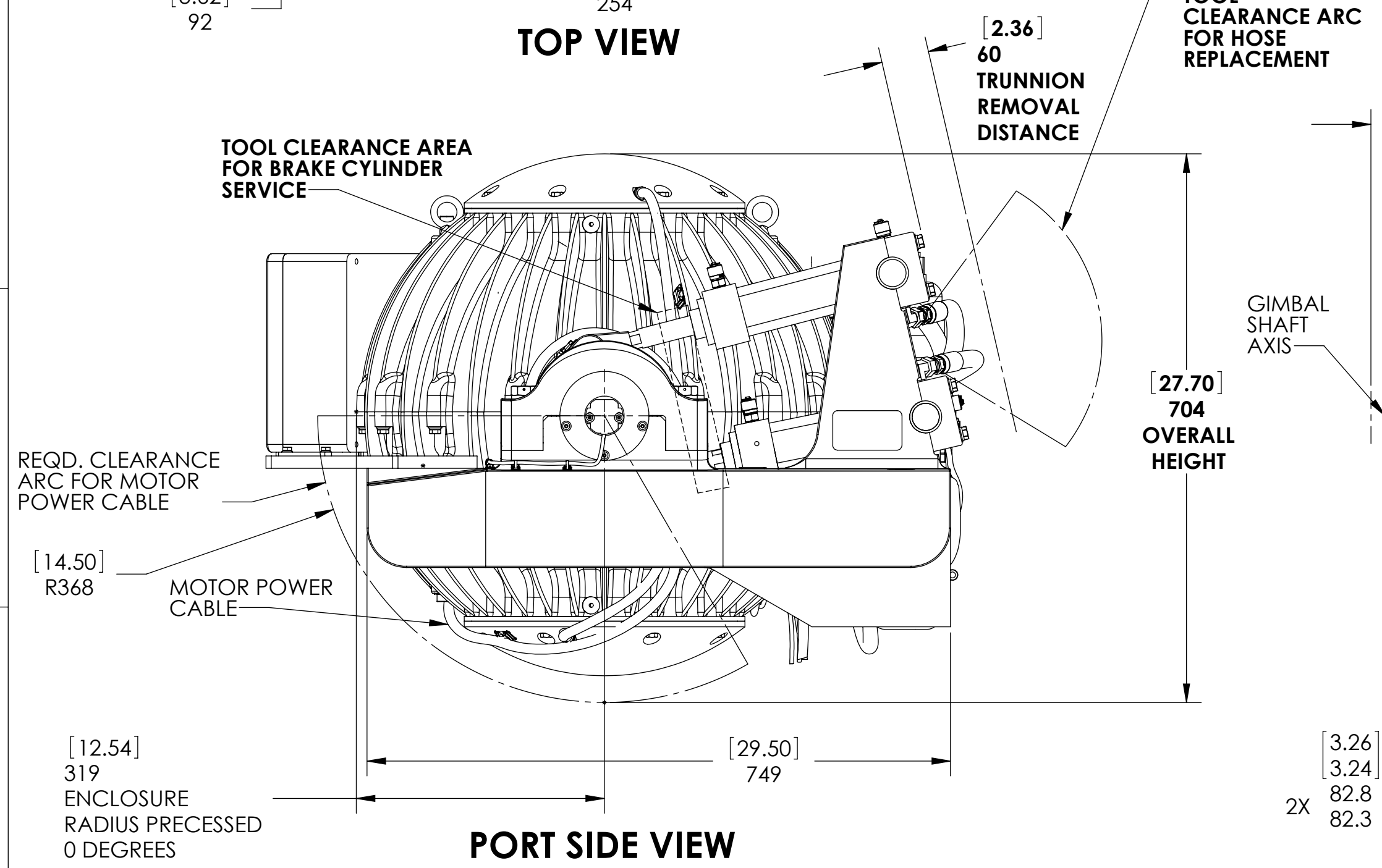
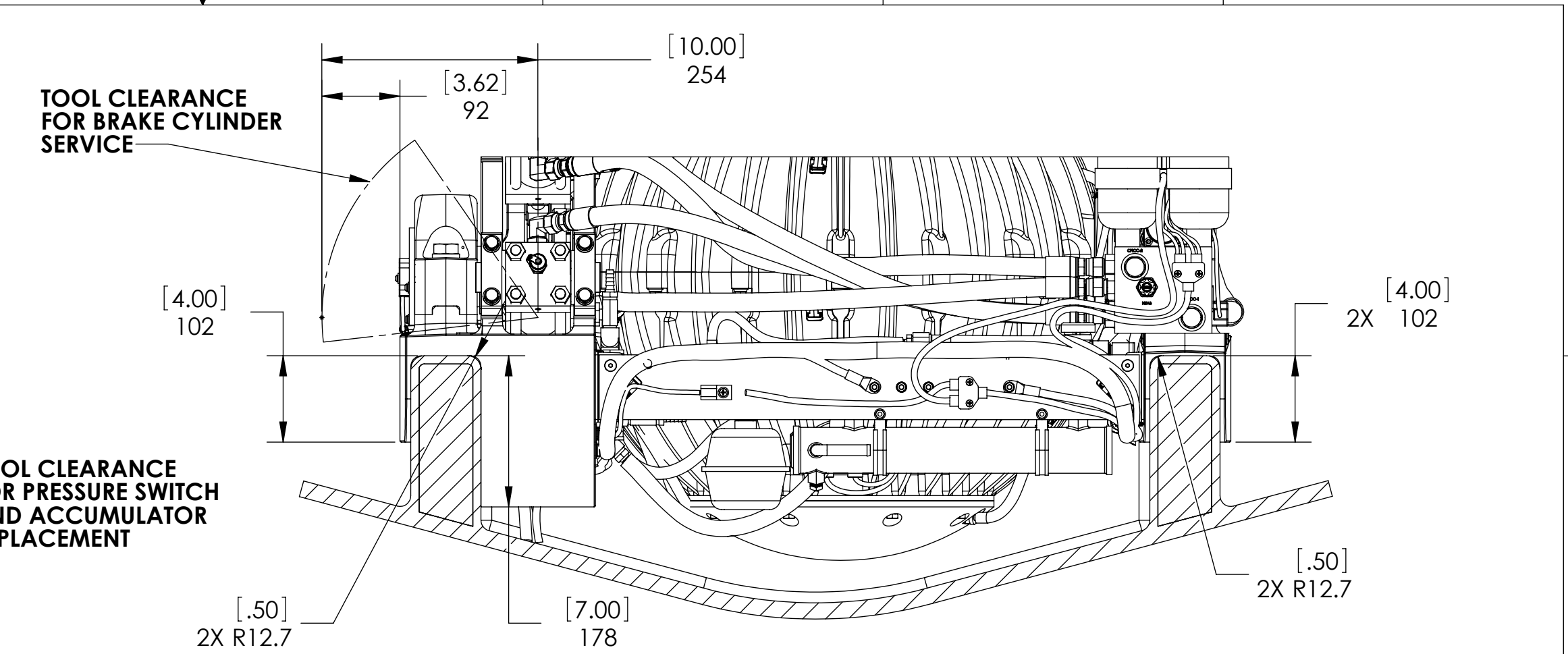
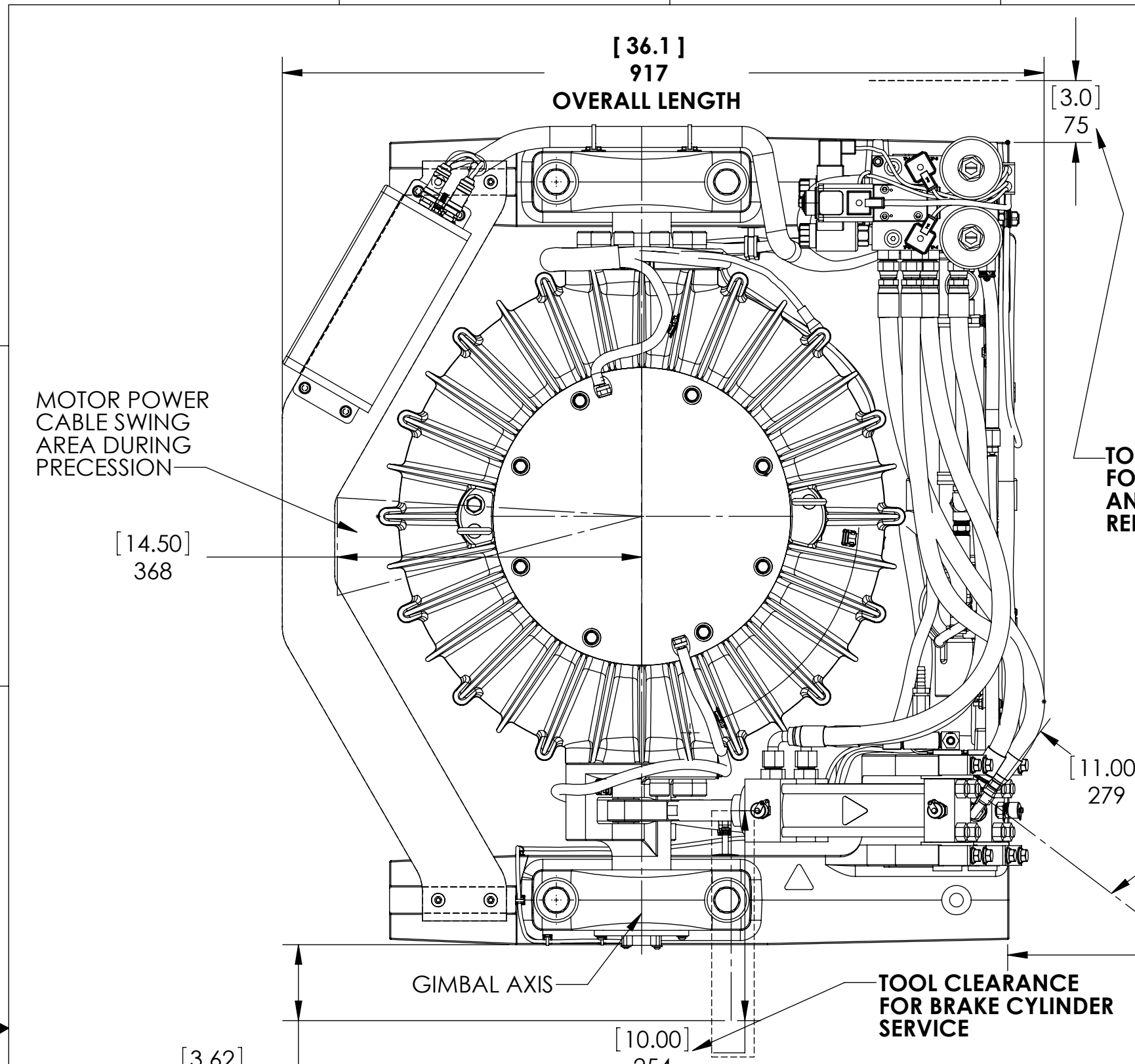

SIZE <b>C</b>	DWG. NO. <b>90031</b>	REV <b>3</b>
SCALE: 1:10	WEIGHT:	SHEET 2

8

7

6

5

4

3

2

1

F

E

D

C

B

A

F

E

D

C

B

A

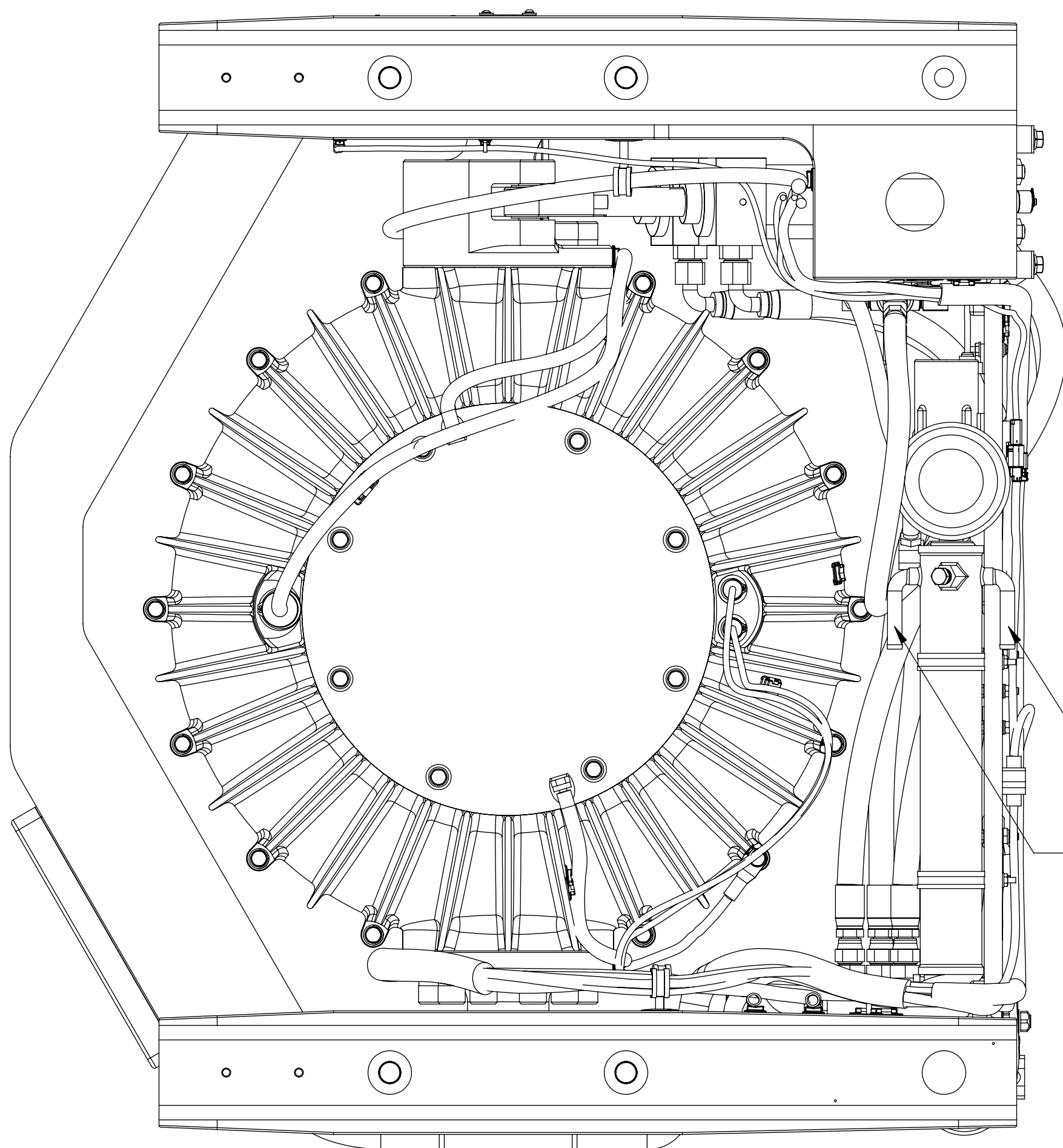

**BOTTOM VIEW**

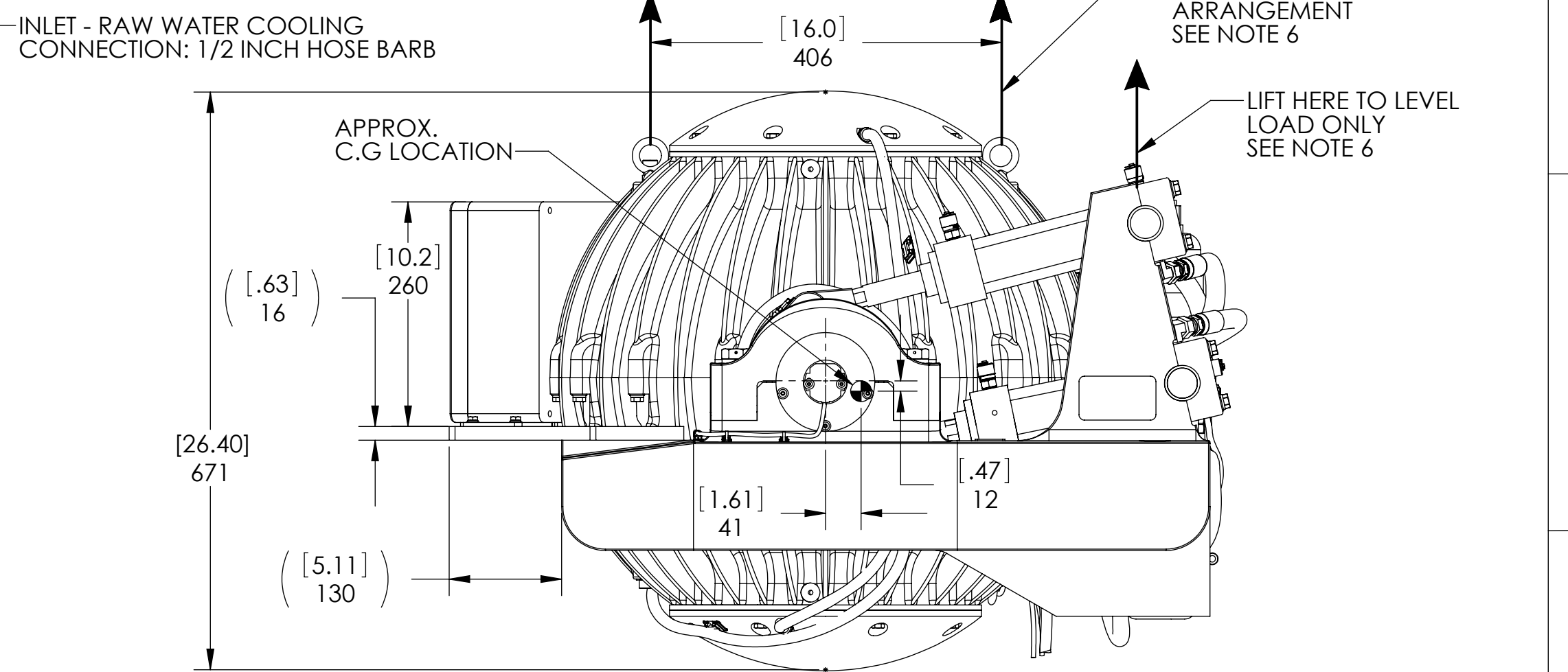
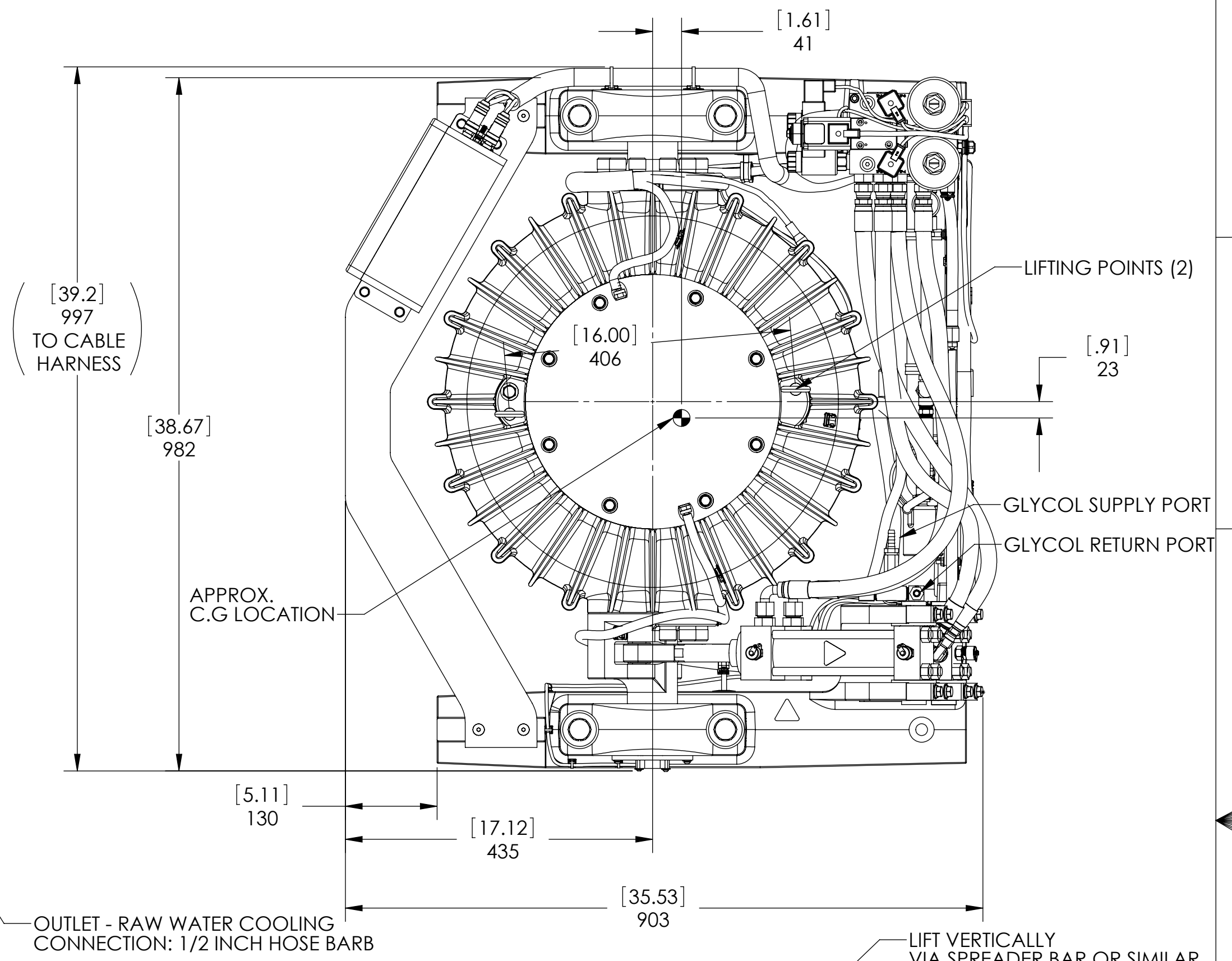

SIZE <b>C</b>	DWG. NO. <b>90031</b>	REV <b>3</b>
SCALE: 1:10	WEIGHT:	SHEET 3

8

7

6

5

4

3

2

1

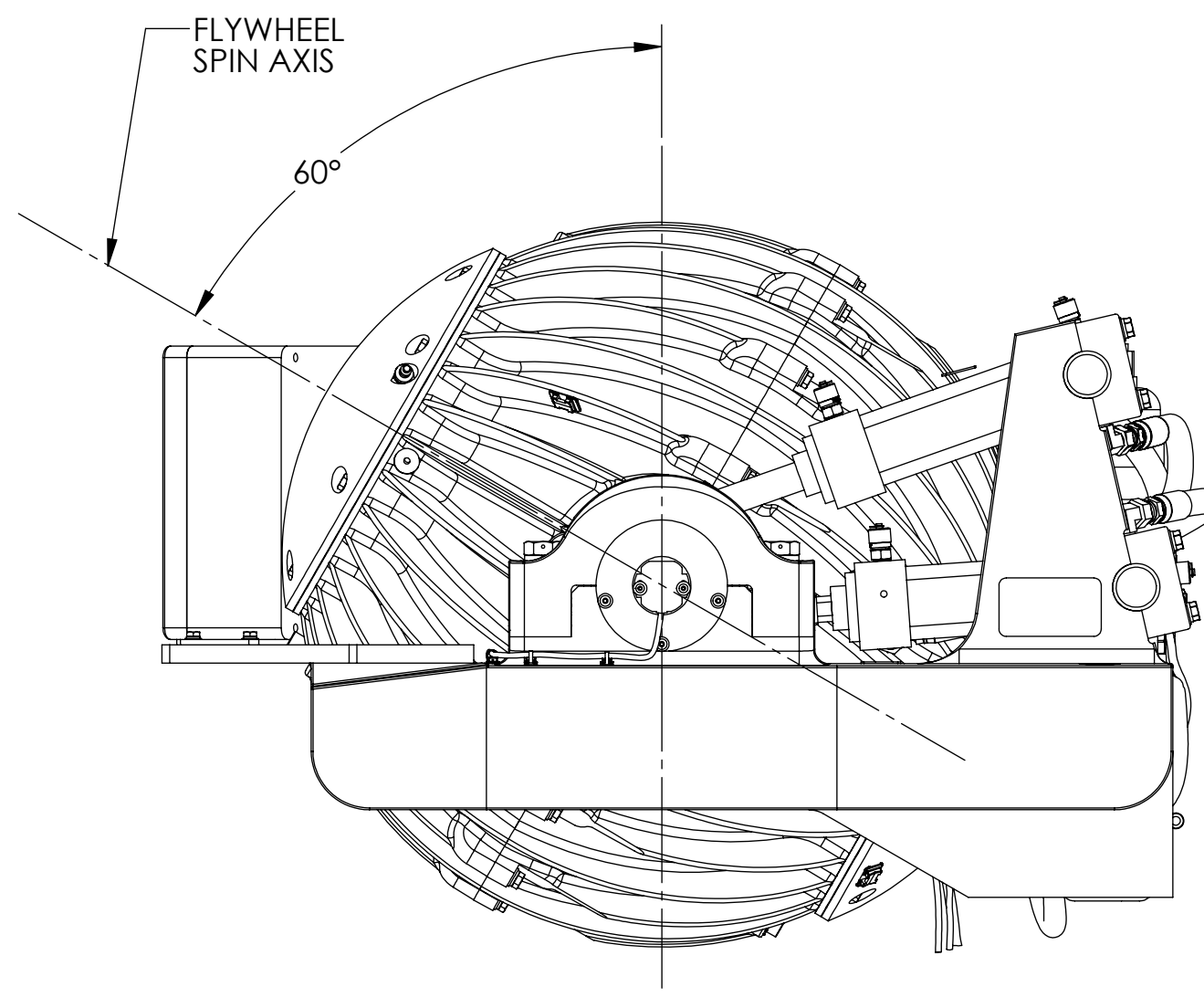
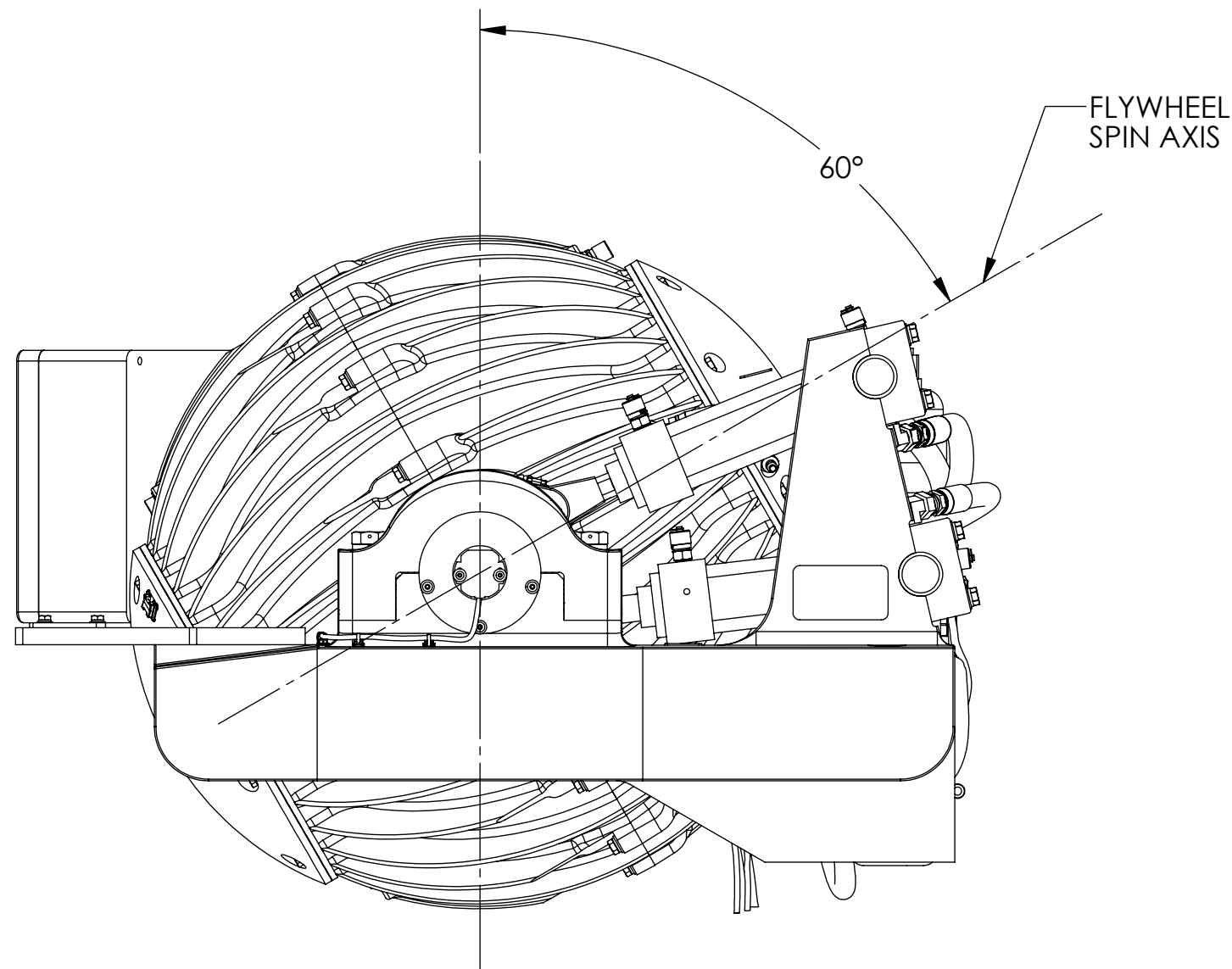
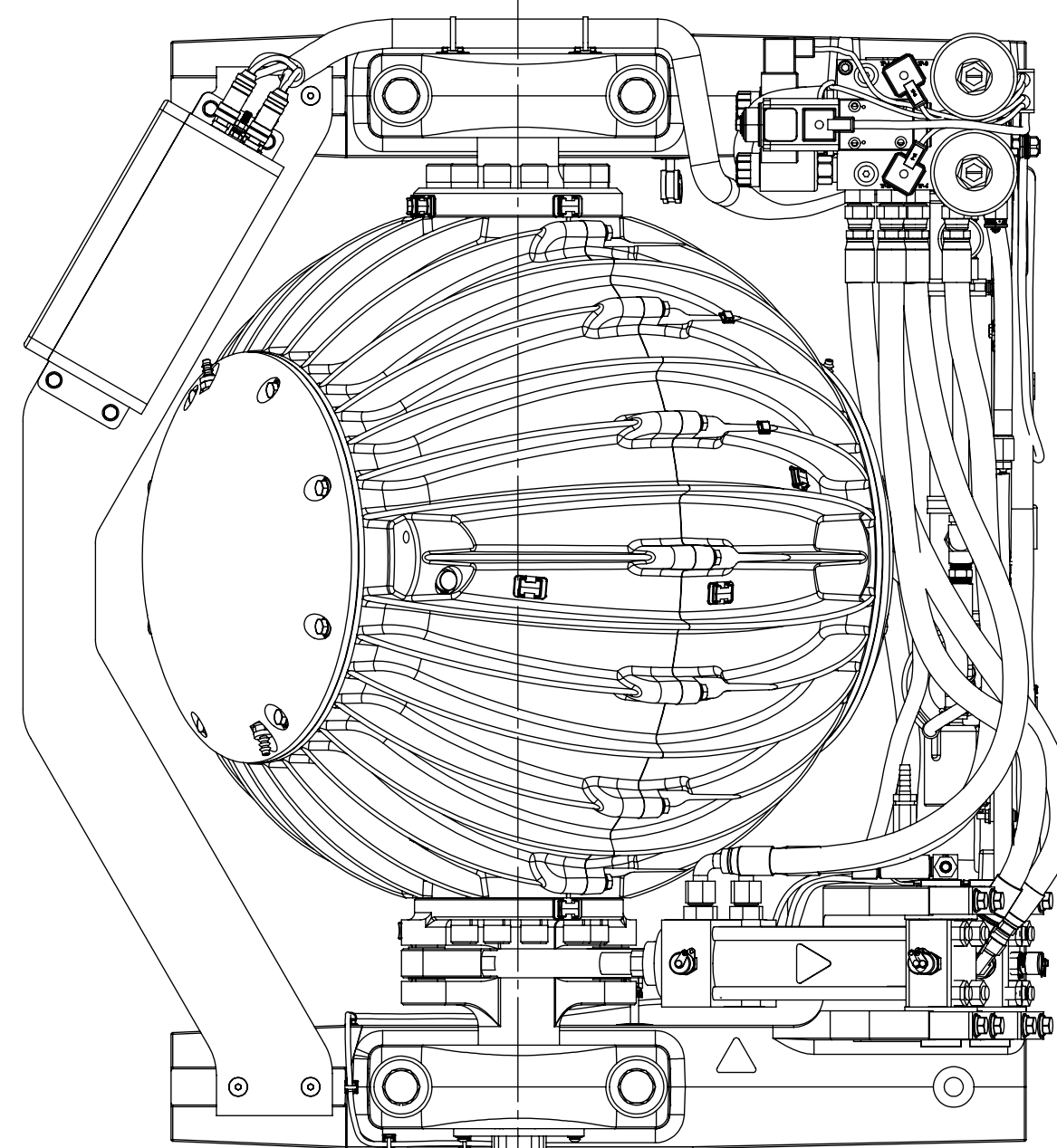
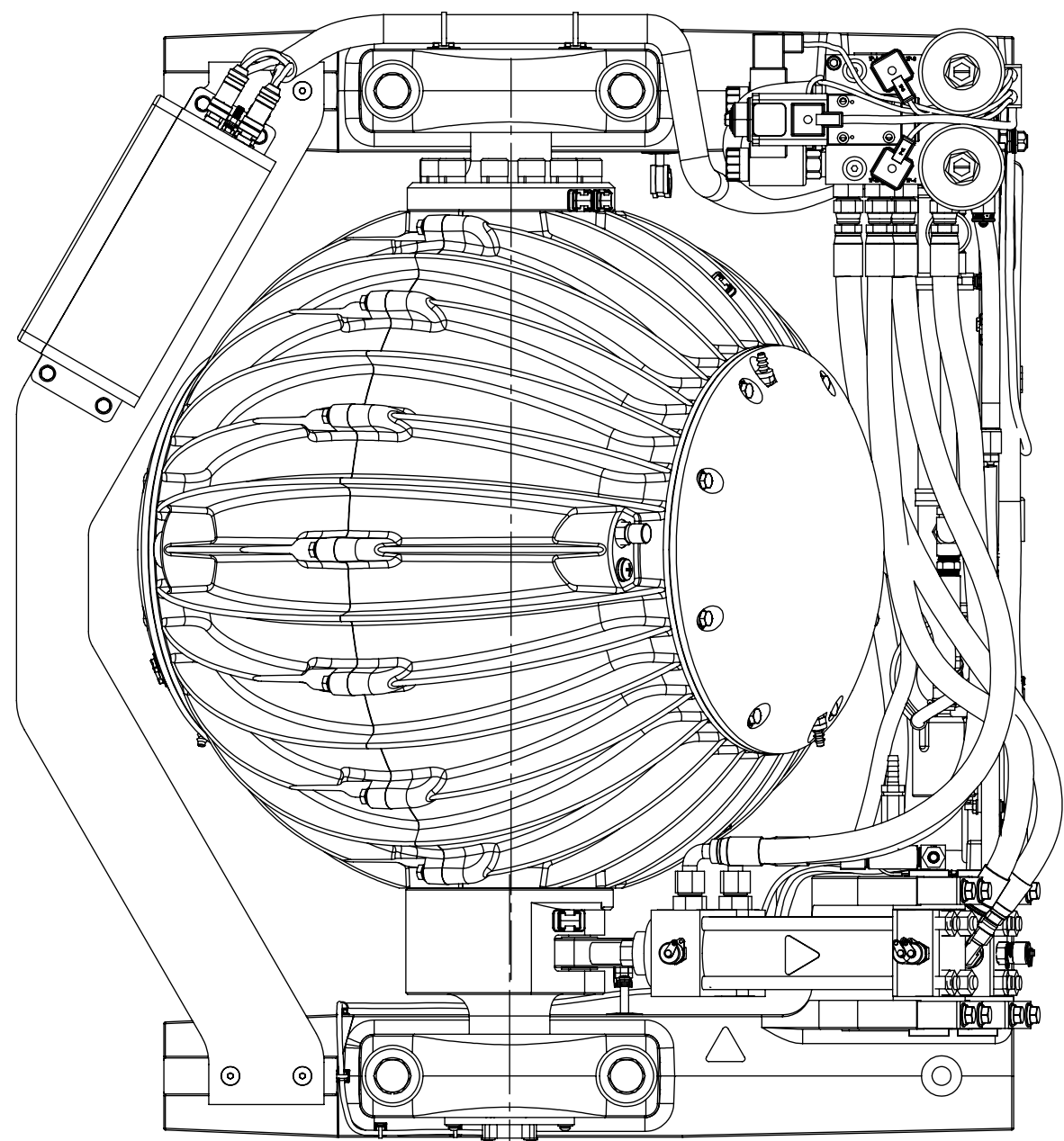

**GYRO SHOWN PRECESSED TO POSITIVE LIMIT (+60 °)**

**GYRO SHOWN PRECESSED TO NEGATIVE LIMIT (-60 °)**

SIZE <b>C</b>	DWG. NO. 90031	REV <b>3</b>
SCALE: 1:10	WEIGHT:	SHEET 4

8

7

6

5

4

3

2

1

**GYRO LOADS FOR STRUCTURAL DESIGN:**

The Gyro is mounted in two gimbal bearings each of which is supported by an aluminum saddle beam made of A356-T6 cast aluminum. The saddles are designed to be permanently attached to longitudinal GRP hull beams with a structural adhesive. This mounting arrangement distributes the cyclic, fully reversing forces and moments generated by the Gyro over a large surface area. The unit is **not** designed to be bolted to the hull structure and this method of attachment should never be attempted without consultation with Seakeeper.

The Gyro generates pitch moments, roll moments, yaw moments and vertical and horizontal forces - the magnitude of which is controlled by the Gyro's active brake system. These Gyro generated forces and moments result in loads being applied at the saddle beam gimbal bearings and at the brake cylinder attachment points on the port saddle beam..

In order to simplify structural analysis of the hull foundation that supports the saddle beams, these latter forces and moments have been resolved into resultant forces and moments at a single point. Also, for simplicity, they have been reduced to a single force set, from examination of a large number of possible loading combinations. The reference point is the intersection of the gimbal axis and the centerline plane of the port beam. The resultant forces and moments at this point are illustrated on the adjacent figure and values to be used for foundation design are summarized below:

- Pitch Moment (M) = 5.6 kN - M [4100 Ft-Lb]
- Yaw Moment (N) = 1.2 kN - M [900 Ft-Lb]
- Vertical Force (Fz) = 23.5kN [5300 Lb]
- Longitudinal Force(Fx) = 9.5kN [2100 Lb]
- Lateral Force (Fy) = 4.4 kN [1000 Lb]

These forces and moments should be considered to be:

- Acting simultaneously
- Fully reversing (i.e., acting in either direction)
- Repeated an infinite number of times
- Applicable to the starboard beam even though it does not have brake cylinders

The boat builder or the gyro installer is responsible for designing the hull foundation to which the gyro is attached to accommodate the above forces and moments plus a reasonable Factory of Safety. A Factor of Safety of 3.0 (Margin of Safety of 2) is suggested.

The boat builder or gyro installer is also fully responsible for selecting the structural adhesive to secure the aluminum saddle beams to the GRP hull beams. The calculated shear stress in the structural adhesive between the saddles and the hull foundation beams for the above loads and 100% adhesive contact is 2.3 MPa (337 psi). Seakeeper recommends that the builder or installer use a structural adhesive with a minimum shear strength of 13.8 MPa (2000 psi) to give a Factor of Safety of 6 (Margin of Safety of 5). Additionally, it is strongly suggested that the builder or installer test the compatibility of his structural adhesive with cast A356 T6 aluminum and his hull materials by doing mechanical property tests.

Bond areas are listed below to help aid in determining the quantity of adhesive required.

- Port Saddle bond area: 340 square inches (2194 square cm)
- Starboard Saddle bond area: 310 square inches (2002 square cm)

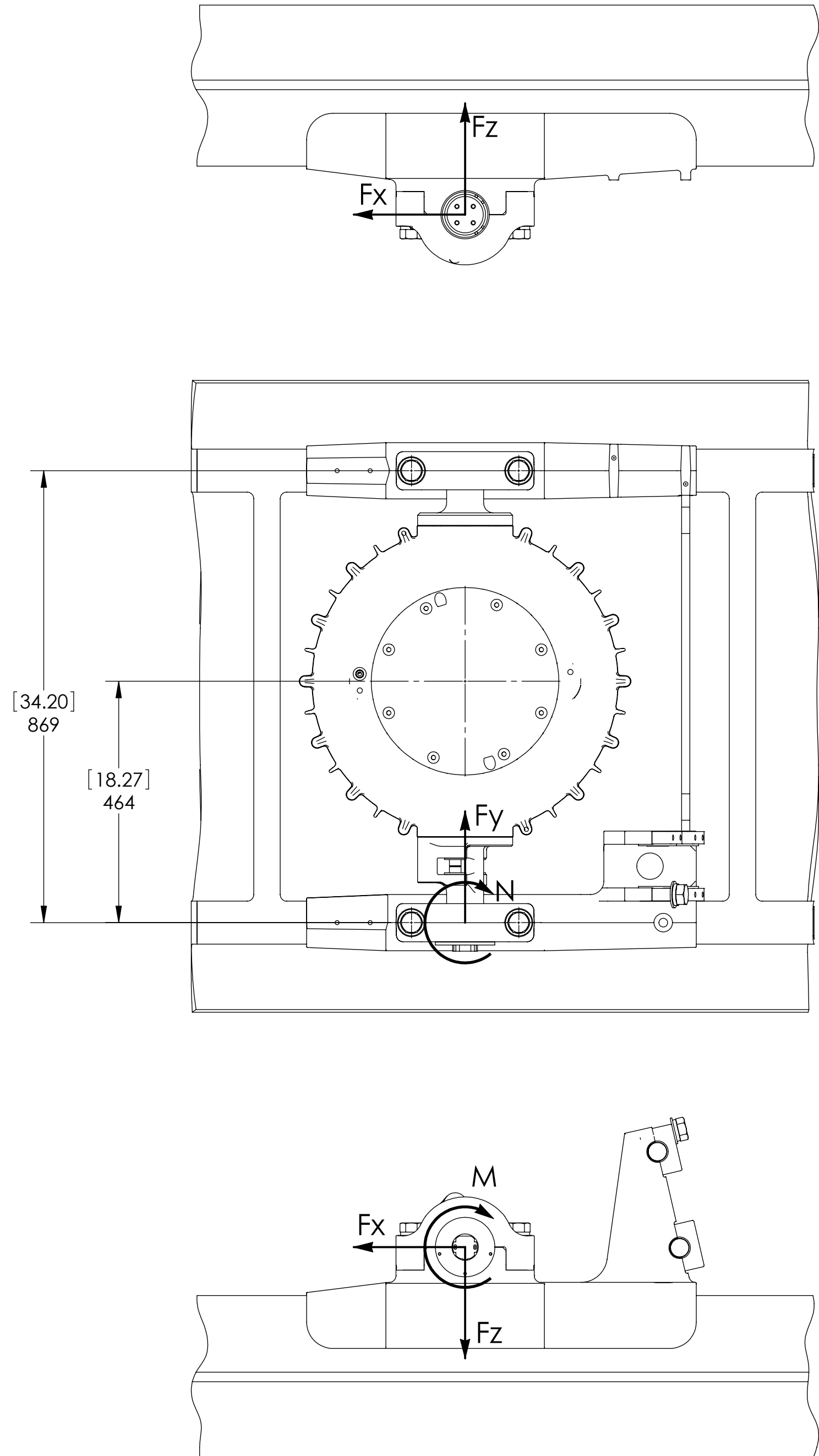

SIZE <b>C</b>	DWG. NO. 90031	REV <b>3</b>
SCALE: 1:10	WEIGHT:	SHEET 5