

NOTES:

- 1) DRAWING OF INSTALLATION JIG ASSEMBLY SUPPLIED BY SEAKEEPER, INC. JIG IS INTENDED TO HELP THE BOAT BUILDER PREPARE VESSEL STRUCTURE FOR GYRO INSTALLATION.
- 2) DIMENSIONS GIVEN FOR WIDTH OF SADDLES ARE THE MAXIMUM INSIDE WIDTH AND THE MINIMUM OUTSIDE DIMENSION TO EACH SADDLE VERTICAL SURFACE.
- 3) MAXIMUM ALLOWABLE GAP BETWEEN INSTALLATION JIG AND VESSEL STRUCTURE IS DETERMINED BY SELECTED ADHESIVE MANUFACTURERS REQUIREMENTS. SEE SEAKEEPER INSTALLATION DETAILS DRAWING FOR THE MODEL GYRO BEING INSTALLED.

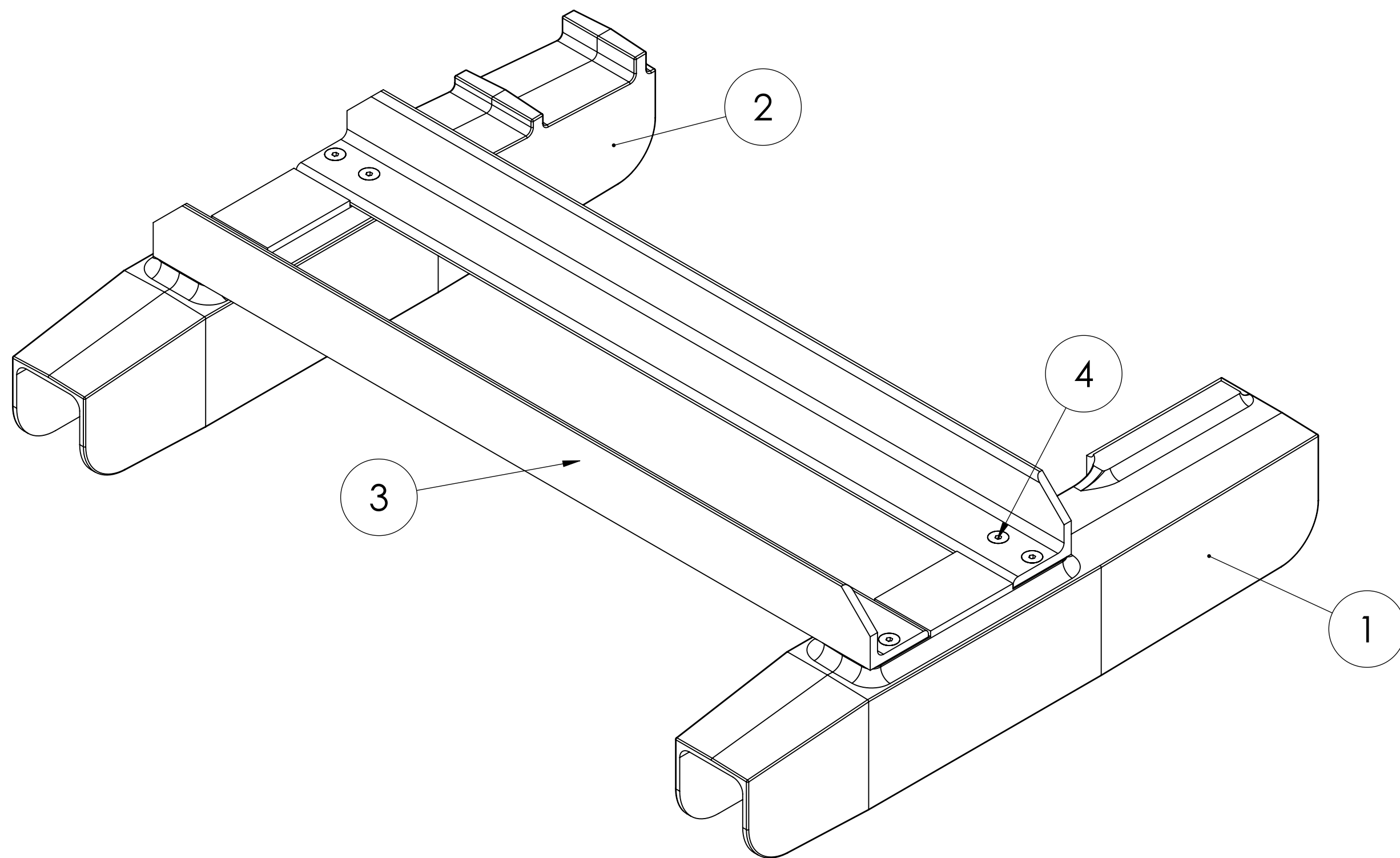

REVISIONS			
REV.	DESCRIPTION	DATE	APPROVED
2	1. ADDED LABEL (ITEM 5) 2. REMOVED GYRO MODEL # & DRAWING # FROM NOTES. 3. REMOVED REV AND SUPPLIER COLUMNS FROM BOM.	08JUN09	WED BRD



ITEM	SEAKEEPER PART NO.	DESCRIPTION	QTY
5	40158	LABEL - INSTALLATION JIG	1
4	60066	FLAT SKT HEAD CAP SCREW, 3/8-16 X 1 LG	8
3	10333	INSTALLATION JIG ANGLE	2
2	10332	SADDLE CASTING FOR INST. JIG	1
1	10331	BRAKE SADDLE CASTINGS FOR INST. JIG	1

UNLESS OTHERWISE SPECIFIED:
DIMENSIONS ARE IN MILLIMETERS
TOLERANCES:
-TWO PLACE DECIMAL
-THREE PLACE DECIMAL
-ALL DIAMETERS RUNOUT TO DATUM SURFACES
-ALL FACES PERPENDICULAR TO DATUM SURFACES
-ALL EDGE BREAKS
-ALL FILLET RADII
-SURFACE FINISH

THIRD ANGLE PROJECTION

PROPRIETARY AND CONFIDENTIAL

THE INFORMATION CONTAINED IN THIS DRAWING IS THE SOLE PROPERTY OF SEAKEEPER, INC. ANY REPRODUCTION IN PART OR AS A WHOLE WITHOUT THE WRITTEN PERMISSION OF SEAKEEPER, INC. IS PROHIBITED.

DO NOT SCALE DRAWING

	NAME	DATE
DRAWN	BHS	13FEB08
CHECKED	WED	18SEPT09
ENG APPR.	JDA	18SEPT09

SEAKEEPER
P.O. BOX 999
SOLOMONS, MARYLAND 20688, USA
PHONE: (410) 326-1590 FAX: (410) 326-1199

TITLE:
**MODEL 7000 / 7000A GYRO
INSTALLATION JIG ASSEMBLY**

SIZE C	DWG. NO. 90012	REV 2
------------------	--------------------------	-----------------

SCALE: 1:10 WEIGHT: 65.04 LBS (29.5 kg) SHEET 1 OF 2

8

7

6

5

4

3

2

1

F

E

D

C

B

A

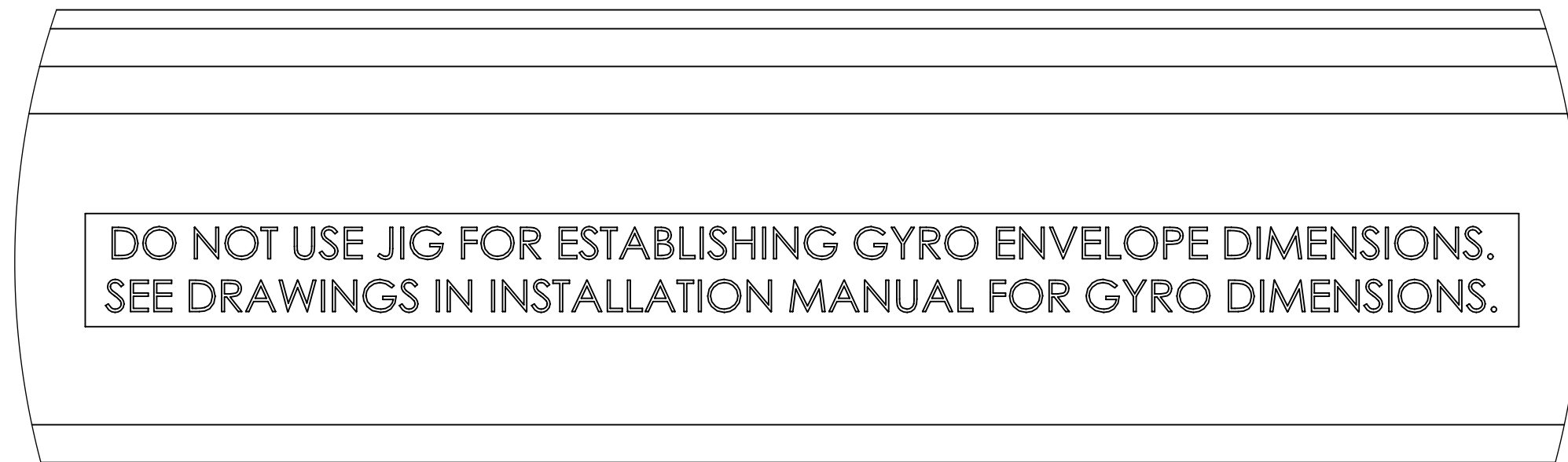
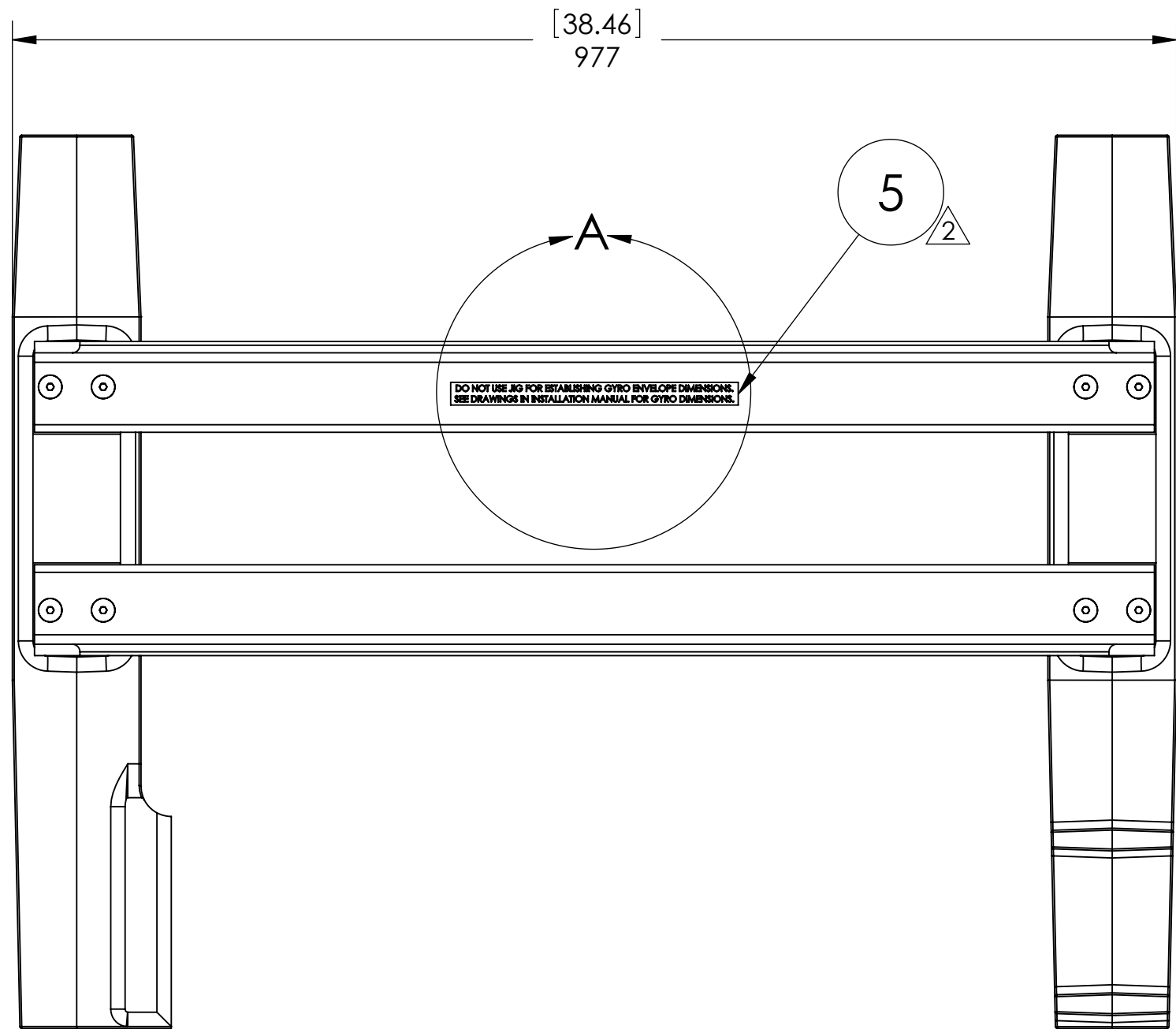

DETAIL A

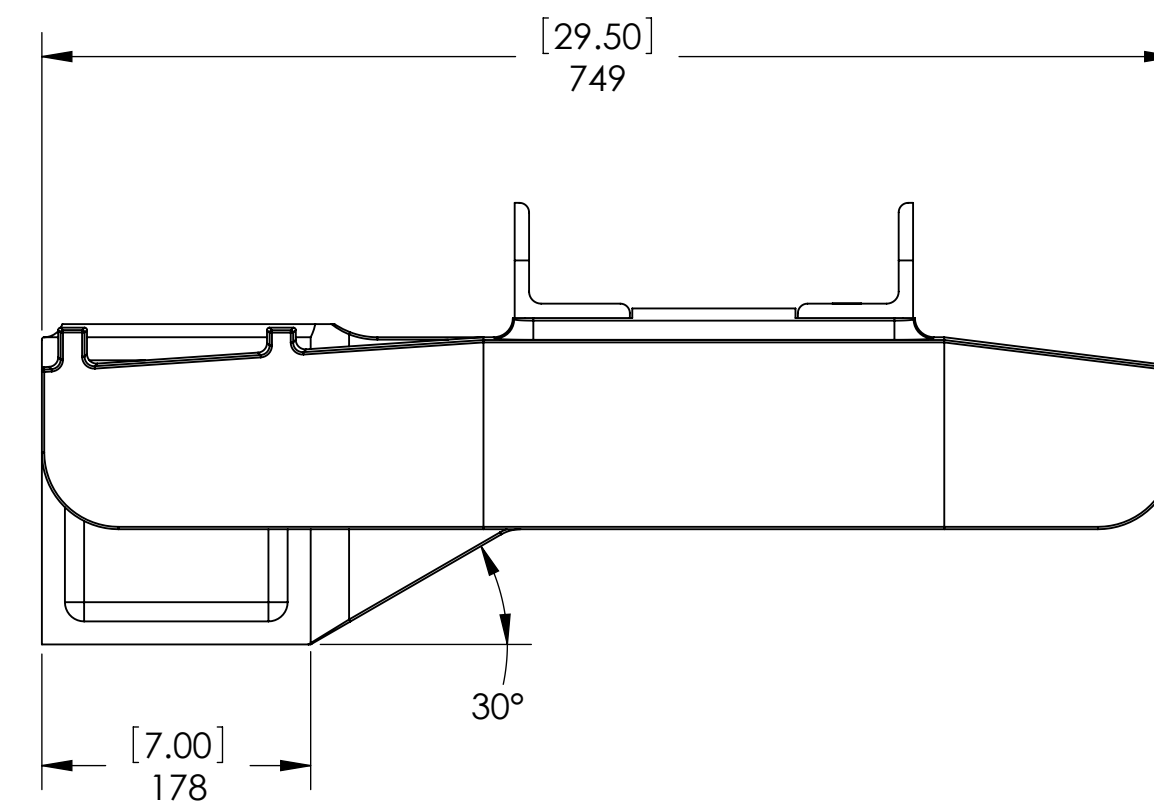
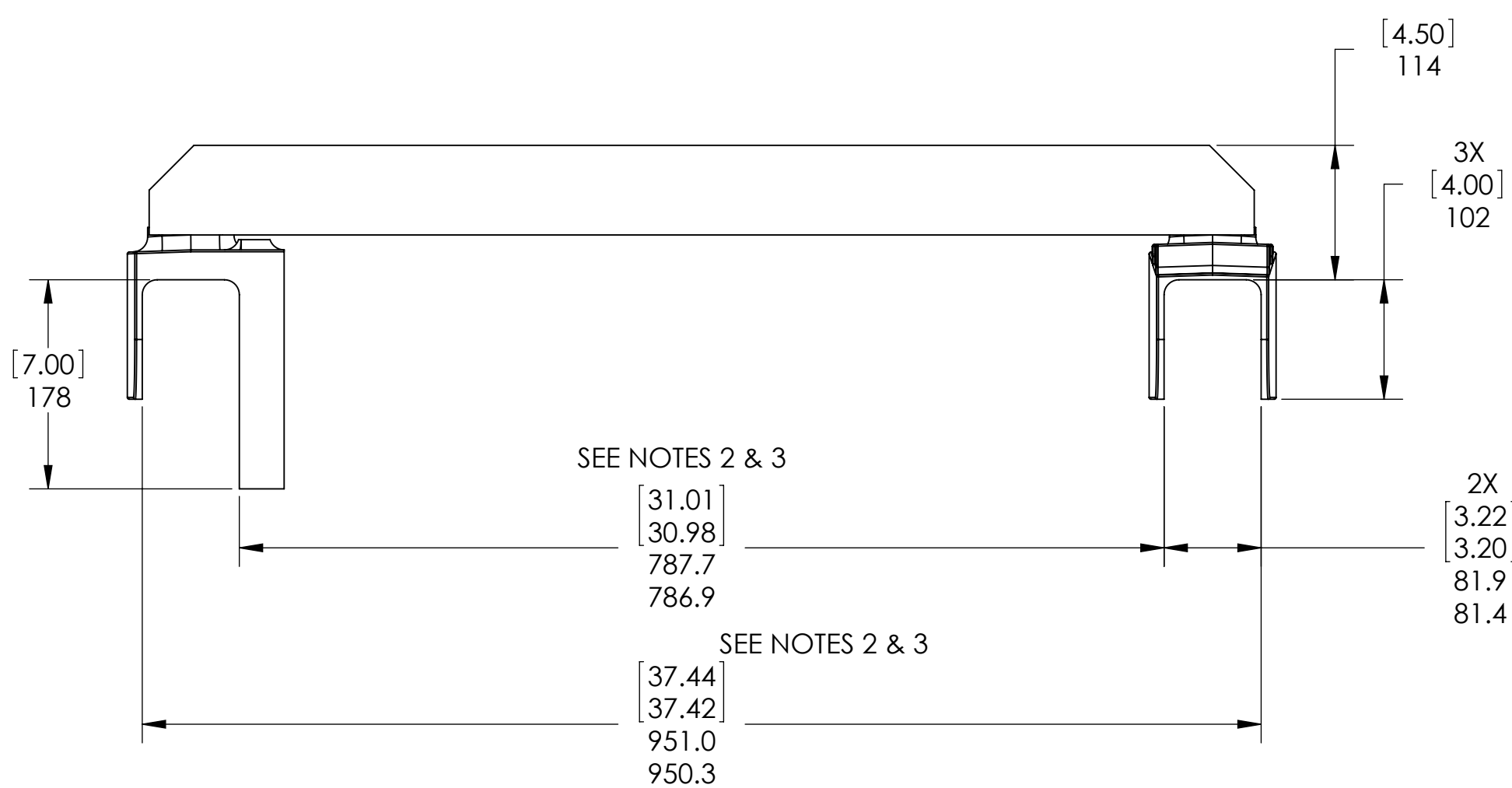

SIZE C	DWG. NO. 90012	REV 2
SCALE: 1:10	WEIGHT: 65.04	SHEET 2

8

7

6

5

4

3

2

1