

NOTES:

- 1) THE COOLANT CIRCUIT WILL BE FILLED WITH A 50% ETHYLENE GLYCOL / 50% DISTILLED WATER MIXTURE.
- 2) SEA WATER FLOW REQUIREMENT THROUGH HEAT EXCHANGER IS 4 GPM (15.1 LPM) OR GREATER, UNDER **ALL OPERATING CONDITIONS OF THE BOAT**. MAXIMUM SEA WATER PRESSURE TO BE 100 PSI (6.9 BAR). WHEN SIZING SEA WATER PUMP, INSTALLER SHOULD FACTOR IN LOSSES FOR RAW WATER PLUMBING. IN ADDITION TO INITIAL OPERATION AT DOCK, NEW GYRO INSTALLATIONS SHOULD BE CHECKED FOR MINIMUM 4 GPM (15.1 LPM) FLOW WHILE VESSEL IS AT SPEED AND WHEN BACKING DOWN.
- 3) CONNECTIONS FOR SEA WATER INLET /OUTLET ARE 3/4 INCH (19 mm) DIAMETER HOSE BARBS.
- 4) IF USING POWER FROM GYRO DRIVE BOX TO OPERATE SEAWATER PUMP, PUMP SHOULD BE 220VAC AND DRAW 5 AMPS MAX . DRIVE BOX USES A 5 AMP RESETTABLE BREAKER SO PUMP SHOULD BE RATED ACCORDINGLY.

REVISIONS				
REV.	ZONE	DESCRIPTION	DATE	APPROVED
2		1. ADDED SHEET 2 / FIGURE TO DRAWING. 2. ADDED NOTE 4 TO DRAWING.	22JUN11	BHS JDA

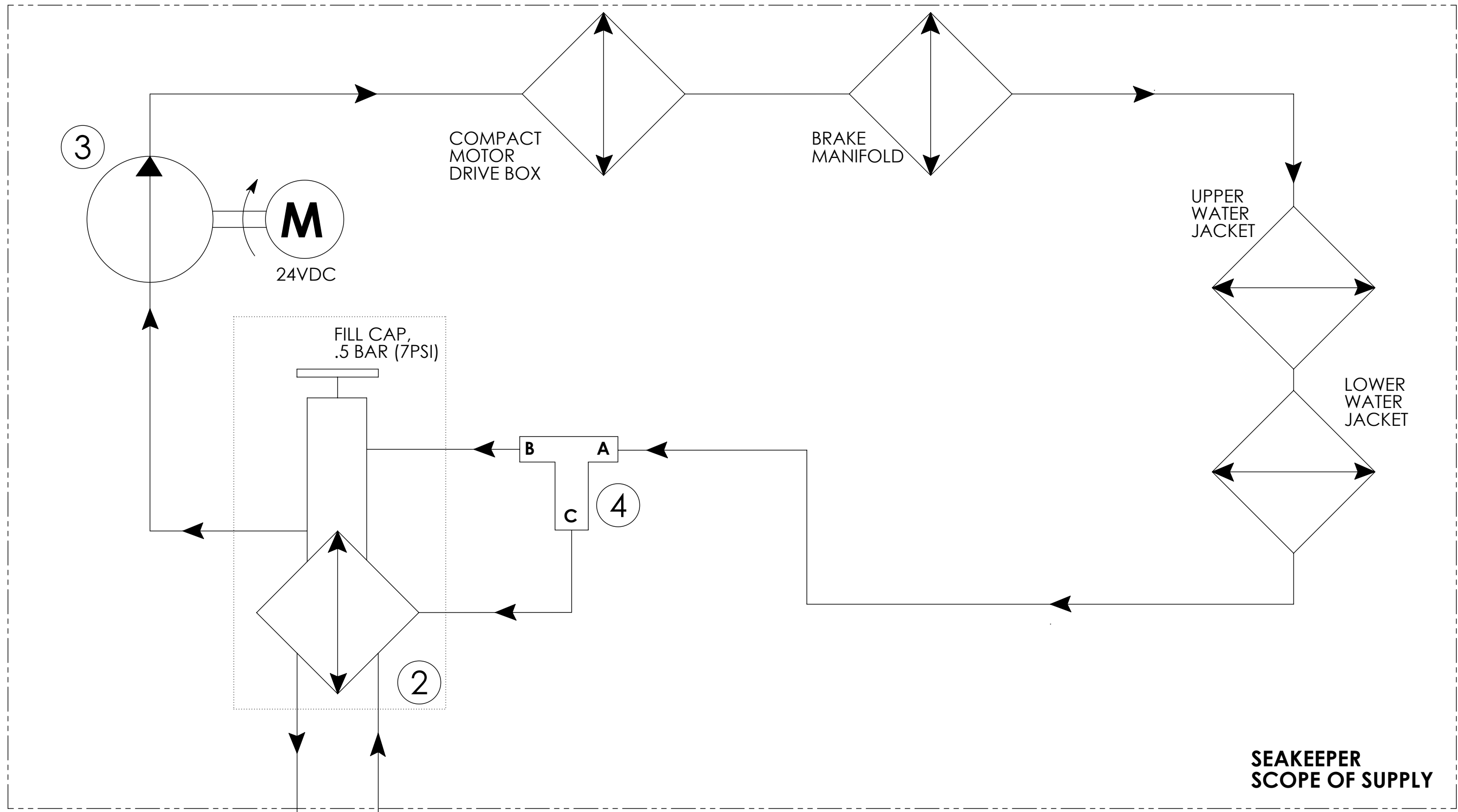

ITEM	SEAKEEPER PART NO.	REV	DESCRIPTION	SUPPLIER
4	40194	-	THERMOSTATIC VALVE	SEAKEEPER
3	20158	-	COOLANT CIRCULATION PUMP	SEAKEEPER
2	40252	-	HEAT EXCHANGER W/INTEGRAL COOLANT RESERVOIR	SEAKEEPER
1	-		SEA WATER PUMP, SEE NOTE 2	BUILDER

THIRD ANGLE PROJECTION

PROPRIETARY AND CONFIDENTIAL

THE INFORMATION CONTAINED IN THIS DRAWING IS THE SOLE PROPERTY OF SEAKEEPER, INC. ANY REPRODUCTION IN PART OR AS A WHOLE WITHOUT THE WRITTEN PERMISSION OF SEAKEEPER, INC. IS PROHIBITED.

UNLESS OTHERWISE SPECIFIED:  
DIMENSIONS ARE IN INCHES  
TOLERANCES:  
-TWO PLACE DECIMAL ±0.01  
-THREE PLACE DECIMAL ±.005  
-ALL DIAMETERS RUNOUT TO DATUM SURFACES .005 MAX  
-ALL FACES PERPENDICULAR TO DATUM SURFACES .005 MAX  
-ALL EDGE BREAKS .010-.020 X 45°  
-ALL FILLET RADII .010-.020  
-SURFACE FINISH

DO NOT SCALE DRAWING

NAME	DATE
DRAWN BRD	12APR11
CHECKED KDF	26APR11
ENG APPR. JDA	26APR11

**SEAKEEPER**™

P.O. BOX 809  
CALIFORNIA, MARYLAND 20619, USA  
PHONE: (410) 326-1590 FAX: (410) 326-1199

TITLE: **MODEL 8000 GYRO COOLING WATER SCHEMATIC**

SIZE <b>C</b>	DWG. NO. <b>90156</b>	REV <b>2</b>
SCALE: 1:1	WEIGHT:	SHEET 1 OF 2

# GENERAL RECOMMENDATIONS FOR GYRO COOLING CIRCUIT:

- 1) SEAKEEPER RECOMMENDS A CONTINUOUS DUTY CENTRIFUGAL STYLE PUMP FOR THIS APPLICATION.
- 2) A SELF PRIMING PUMP IS NOT REQUIRED IF THE PUMP IS LOCATED WELL BELOW VESSEL'S STATIC (ZERO SPEED) AND UNDERWAY WATERLINE.
- 3) SEA WATER PUMP SHOULD BE APPROPRIATELY SIZED TO ACCOUNT FOR PLUMBING LOSSES BETWEEN PICK-UP AND GYRO HEAT EXCHANGER.
- 4) THE PUMP MUST NOT BE AT A LOCAL HIGH POINT THAT CAN TRAP AIR AND PREVENT PROPER OPERATION. THE DISCHARGE HOSE OF THE PUMP SHOULD BE ROUTED CONTINUOUSLY UPHILL AS MUCH AS PRACTICAL TO ALLOW PUMP TO MAINTAIN PRIME SHOULD A SMALL AMOUNT OF AIR ENTER THE PLUMBING.
- 5) SEA WATER PUMP SHOULD BE RATED FOR SAME MAXIMUM SEA WATER TEMP(35°C) AND AMBIENT AIR TEMPERATURE (60°C) AS GYRO.
- 6) FOR MULTIPLE GYRO INSTALLATIONS, ONE SEA WATER PUMP PER INSTALLED GYRO IS RECOMMENDED.
- 7) SEA WATER SCOOP INTAKE SHOULD FACE FORWARD AND SHOULD NOT BE LOCATED NEAR PROPELLERS OR BEHIND HULL PROTRUSIONS THAT WILL DISTURB FLOW.
- 8) SEA WATER PUMP SHOULD BE POWERED VIA CABLE#8 FROM GYRO MOTOR DRIVE BOX.

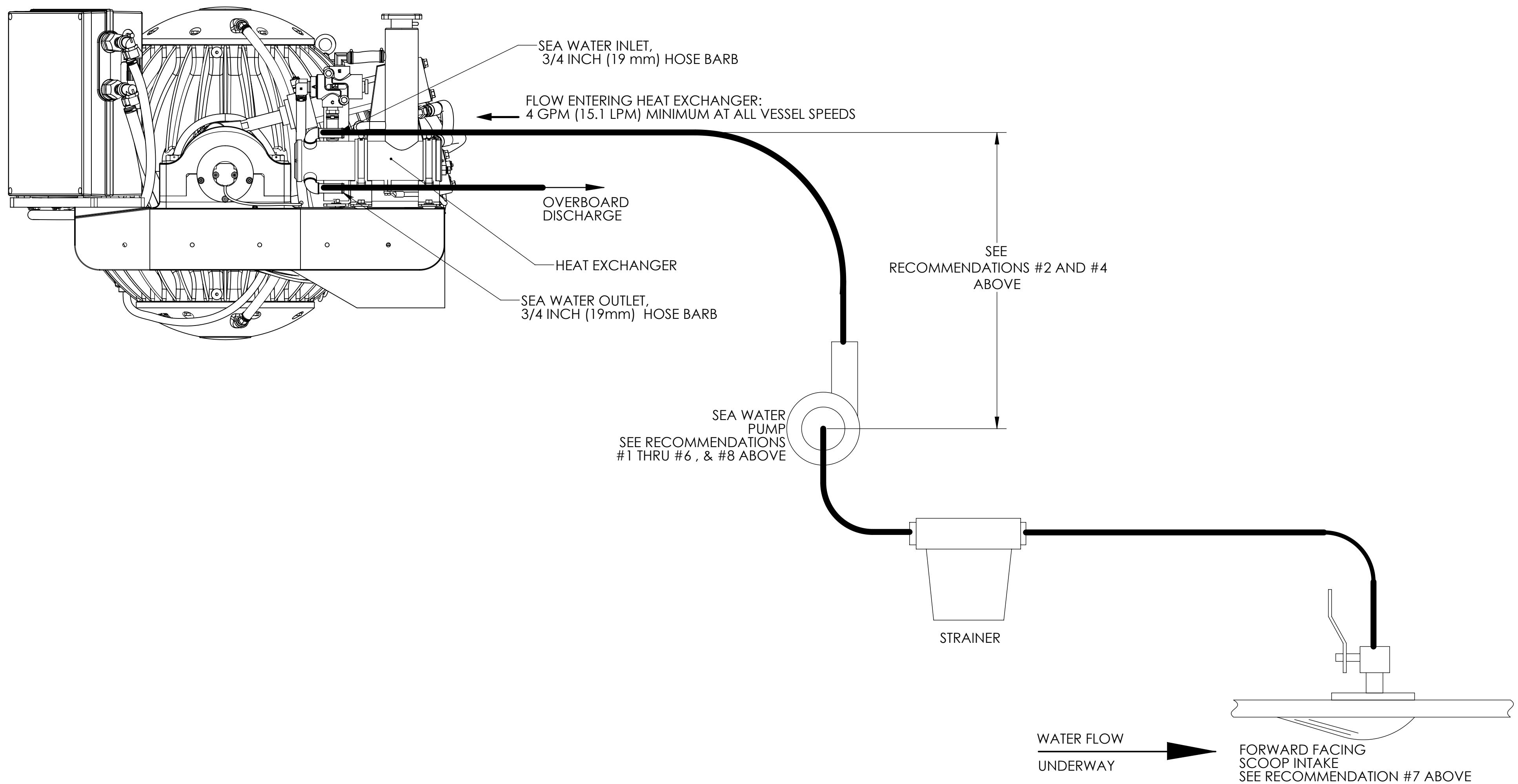

SIZE <b>C</b>	DWG. NO. <b>90156</b>	REV <b>2</b>
SCALE: 1:10	WEIGHT:	SHEET 2