

Silent Stability

When the world leader in active gyroscope (gyro) stabilizer technology needed a vibration- and sound-reducing solution for its innovative technology, it turned to Simrit. With its extensive materials expertise, Simrit was able to provide Seakeeper with a damping solution that eliminated noise and vibration, while still fitting the existing design, helping Seakeeper continue to silently stabilize the sounds and shudders of the sea.

Modernizing a Century Old Innovation

Seakeeper was formed for a defined purpose. In 2003, the privately funded start-up company was created with the goal of updating gyro stabilizer technology for use on large boats (60 feet and longer). This technology has a long history, dating back to the early 1900s for motion control of ocean vessels, but it was used sparingly due to its weight, size and required power consumption. Using modern technology and materials, Seakeeper knew it could reinvent the gyro to make it far more practical. And that is just what they did! By using

state-of-the-art engineering and manufacturing, Seakeeper was able to modernize the existing gyro technology to reduce the natural roll of a boat by more than 70 percent. This is quite an improvement considering that a boat's natural roll has the potential to be three to five times the slope of a wave. While there are many applications (for example fins, tanks, flopper stoppers) that work to reduce roll at a boat's natural period, an actively controlled gyro is the only stabilization device that will reduce roll at all speeds and sea conditions. According to Seakeeper, its updated gyro innovation – a "Control Moment Gyro" (CMG) – employs the physics of gyro-dynamics. Seakeeper offers two CMG models. Model 8000 is applicable to boats between 40 and 80 feet, while Model 21000 is applicable to boats 80 feet and up (boats over 100 feet typically require multiple gyros). What separates Seakeeper's product from its competitors is that the gyro flywheel operates in a vacuum, which reduces air drag and enables a more efficient system. The system, which is mounted inside the hull structure aft of amidships, has a heavy flywheel that spins at high speed in a near vacuum to produce a gyroscopic torque that exerts a powerful righting torque to counteract boat roll. The unit also includes an active control mechanism, which optimizes the gyro's performance over a wide range of sea states.



As gyroscope specialists luxury yachts are a major market segment for Seakeeper.



Gyroscopes are capable of reducing and virtually eliminating a boat's natural roll.

Seakeeper's updated "Control Moment Gyro" (CMG) relies on Simrit and its microcellular technology for a customized solution.

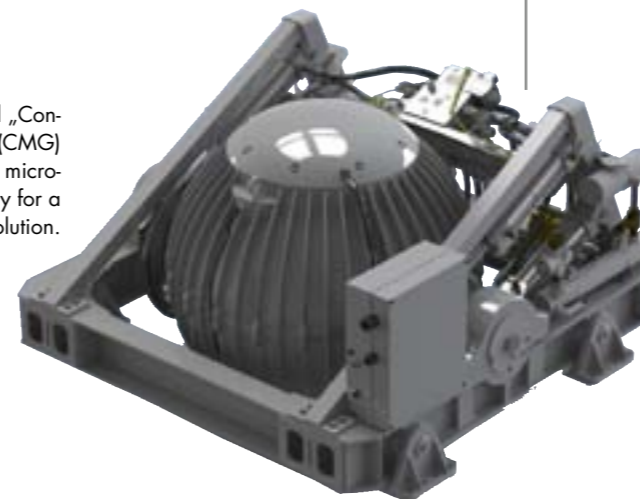

Seakeeper's small, lightweight system is able to virtually eliminate zero and low speed boat roll both when a vessel is anchored and underway. Offering a flexible installation that consumes minimal power, the system requires no through-hull cutting, which eliminates the need for drag-producing and damage-prone appendages. These results provide yacht manufacturers and owners outstanding luxury and performance, without compromised comfort or safety.

The Sounds of Success

Once it established its successful gyro technology, Seakeeper wanted to address the continual "humming" noise produced by the system. With the stabilizer mounted to the hull of the boat, when the gyro spools up, its harmonic

frequencies are transmitted throughout the yacht. These frequencies are transmitted to the cabinets and other interior objects, which in turn act like speakers and cause the humming noise to be amplified. While some would consider this the sweet sounds of success, Seakeeper was determined to damp the vibration and noise of its proven system. A successful anti-vibration mount was developed for the Model 8000 using urethane. However, Seakeeper went looking for a materials expert that had the capabilities to develop and "dial in" the needed material damping character-

Eine Headline bitte

Simrit provided a material for the anti-vibration mounts on our Model 21000 that exceeded our expectations in terms of reducing the transmission of vibration to the hull and the subsequent radiation of noise into the vessel's living spaces. This is particularly important in our main market which is luxury yachts as the owners expect a low ambient noise level regardless of the weather situation or vessel and machinery operating condition. We were impressed with how hard Simrit worked to stay within our envelope requirements and adapt their material to our mounting arrangement. We are now working with Simrit to improve the vibration mount on our Model 8000 Gyro.

John Adams,
Chief Engineer
and Founder of
Seakeeper, Inc.

istics to further reduce the sound when it started developing the Model 21000. Utilizing its materials and testing expertise, Simrit "tuned" its microcellular polyurethane material to meet the needs of the application. Offering superior durability and deflection without the addition of noise and weight, the material solution was further customized to meet the load deflection curves required for the gyro. Using comparative load deflection curve data, the material's stiffness was adjusted to precisely meet the application's requirements. Once developed, the material was tested at the Simrit lab,

as well as on the actual Seakeeper gyro, and was successful in eliminating the unwanted noise from the system. When Seakeeper needed a materials expert it looked to Simrit for a customized solution to improve an already successful design. In addition to addressing the damping issue, Simrit worked within Seakeeper's existing design parameters to provide a more cost-effective, easy to implement solution. Simrit and Seakeeper are now working on an improved anti-vibration mount design for the Model 8000 gyro using Simrit's microcellular technology.

In Brief:

- When Seakeeper needed a material expert, it contacted Simrit to help the cutting-edge company reduce the sound of its successful gyroscope technology.
- Simrit developed a customized material for Seakeeper's precise damping needs that fit into the proven existing gyro application.



Contact: Joe De Popolo,
Joe.DePopolo@simrit.us