



## Technical Bulletin 101

### Supplying Power for the Seakeeper Model 7000 Gyro Stabilizer

The Seakeeper Model 7000 Gyro Stabilizer requires the following power to operate:

**DC Power:** 24 VDC, 10 A

**AC Power:** 208 to 230 VAC, 50/60 Hz, 3 kW, Single-phase

On most boats, the required DC power will be directly available from the boat's battery system and AC power will be directly available from the boat's generator. See the Model 7000 Installation Manual (Document # 90020) for details on proper wiring.

There are however instances where the boat's DC or AC power sources do not directly match those required by the gyro stabilizer system. This Technical Bulletin provides guidance on addressing these instances.

#### *My boat has a 12 VDC battery system. How do I provide 24VDC power for the gyro stabilizer?*

If your boat has a 12 VDC battery system, the simplest means of providing 24 VDC power for the gyro stabilizer is to install an off-the-shelf, marine rated, DC-to-DC converter. This converter should meet the following specifications:

**Input:** 12 VDC

**Output:** 24 VDC, 10 A, 250 W

**Example:** Victron Energy Orion 12/24-10

The converter can be configured as shown in Figure 1. Insure that a qualified electrician does the wiring and follows the installation and wiring instructions provided by the converter manufacturer.

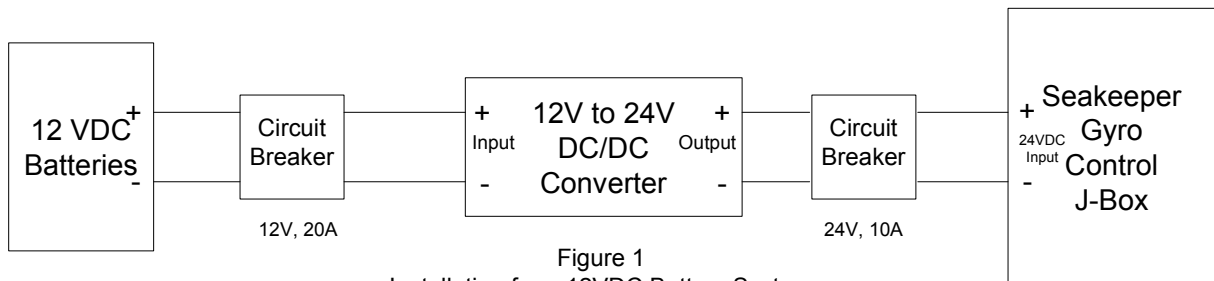
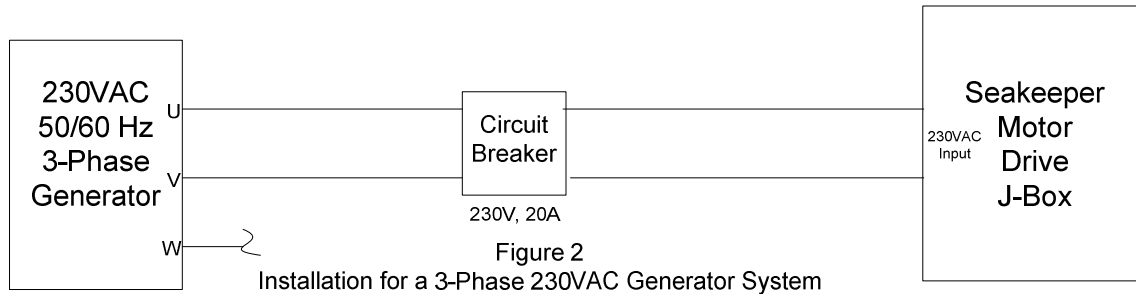

Figure 1  
Installation for a 12VDC Battery System

#### *My boat has a 3-phase, 230 VAC generator. How do I provide single-phase 230 VAC power for the gyro stabilizer?*

Since the gyro stabilizer only requires single-phase power, you can use any phase of the generator to power the gyro stabilizer. See Figure 2. This shows wiring the gyro stabilizer to the U/V phase but it could also be wired to the U/W or V/W phases. Generally when you have a 3-phase power source, you want to balance any single-phase loads between the generator phases. If possible, select a generator phase that optimizes this phase load balance when wiring the gyro stabilizer to a 3-phase generator. Insure that a qualified electrician does the wiring and follows the installation and wiring instructions provided by the generator manufacturer.



***My boat's generator does not have a 230 VAC output. How do I provide 230 VAC power for the gyro stabilizer?***

If your generator does not have a 230 VAC output, it probably provides 115 VAC, 380 VAC, or 480 VAC.

If your generator output is 115 VAC, you have two possible options. In many cases, the generator will actually have a 230 VAC output with a neutral connection. This allows 115 VAC loads to be accommodated by wiring them from one of the 230 VAC lines to neutral. If your 115 VAC generator is configured in this manner, you can provide 230 VAC power for the gyro stabilizer by wiring it line-line on the 230 VAC output rather than wiring line-neutral. See Figure 3. Insure that a qualified electrician does the wiring and follows the installation and wiring instructions provided by the generator manufacturer.

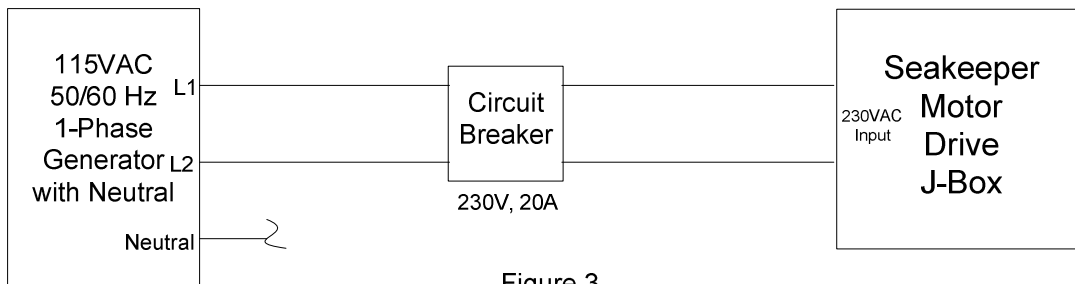

Installation for a Single-Phase 115VAC Generator System w/ available Neutral

If your generator output is 115 VAC but is not configured to provide 230 VAC line-line, a transformer will be required to step the voltage up from 115 VAC to 230 VAC. The transformer should have the following ratings:

- Primary:** 115 VAC      **VA Rating:** 3 kVA
- Secondary:** 230 VAC      **Type:** Marine Grade, Auto or Isolation transformer

The transformer should be configured as shown in Figure 4. Insure that a qualified electrician does the wiring and follows the installation and wiring instructions provided by the generator and transformer manufacturer.

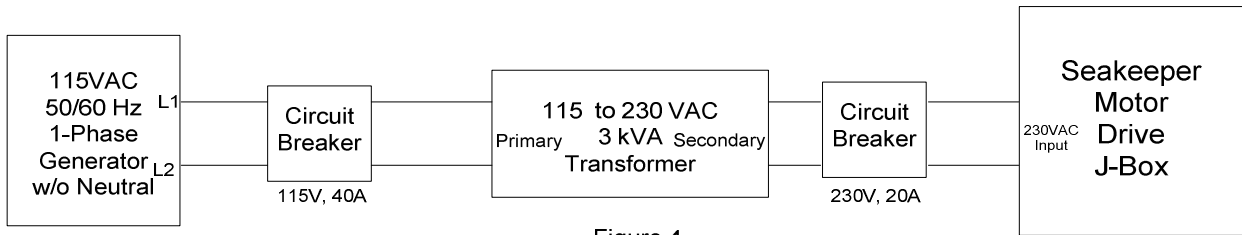

Figure 4  
Installation for a Single-Phase 115VAC Generator System w/o available Neutral

If your generator output is 380 VAC, a transformer will be required to step the voltage down from 380 VAC to 230 VAC. The transformer should have the following ratings:

- Primary:** 380 VAC      **VA Rating:** 3 kVA
- Secondary:** 230 VAC      **Type:** Marine Grade, Auto or Isolation transformer

The transformer should be configured as shown in Figure 5. Insure that a qualified electrician does the wiring and follows the installation and wiring instructions provided by the generator and transformer manufacturer.

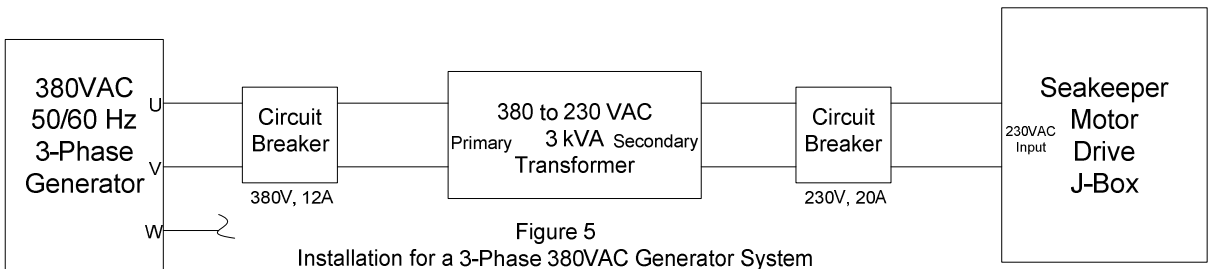

Figure 5  
Installation for a 3-Phase 380VAC Generator System

If your generator output is 480 VAC, a transformer will be required to step the voltage down from 480 VAC to 230 VAC. The transformer should have the following ratings:

- Primary:** 480 VAC      **VA Rating:** 3 kVA
- Secondary:** 230 VAC      **Type:** Marine Grade, Auto or Isolation transformer

The transformer should be configured as shown in Figure 6. Insure that a qualified electrician does the wiring and follows the installation and wiring instructions provided by the generator and transformer manufacturer.

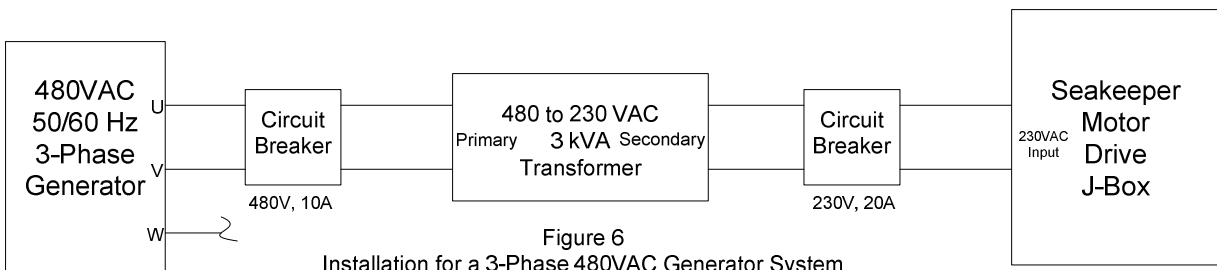

Figure 6  
Installation for a 3-Phase 480VAC Generator System



*During the day, I will power the gyro stabilizer from the generator but at night I would like to turn the generator off and power the gyro stabilizer from the boat's battery system. Can I do this?*

While the gyro stabilizer can be operated overnight on a battery system, it will not be practical on most boat's due to the large battery pack required. To provide power overnight (8 to 10 hours) for the gyro stabilizer requires a 24 VDC deep discharge battery pack with a capacity of at least 1700 Amp-hours. A battery pack of this capacity will weigh approximately 1000 Kg (2200 lbs) and take up over 2.3 m<sup>2</sup> (25 ft<sup>2</sup>) of space. It will also require the addition of a marine inverter with the following capabilities:

**Input:** 24 VDC

**Output:** 230 VAC, 15 A, 3 kW

Figure 7 shows a configuration that would allow the gyro stabilizer to be switched from generator power to inverter power. Note that the batteries and inverter shown are required just to power the gyro stabilizer for 8 to 10 hours. Any other DC loads on the boat would require additional battery capacity. This system will also require a battery charging system capable of recharging the battery pack from the boat's generator.

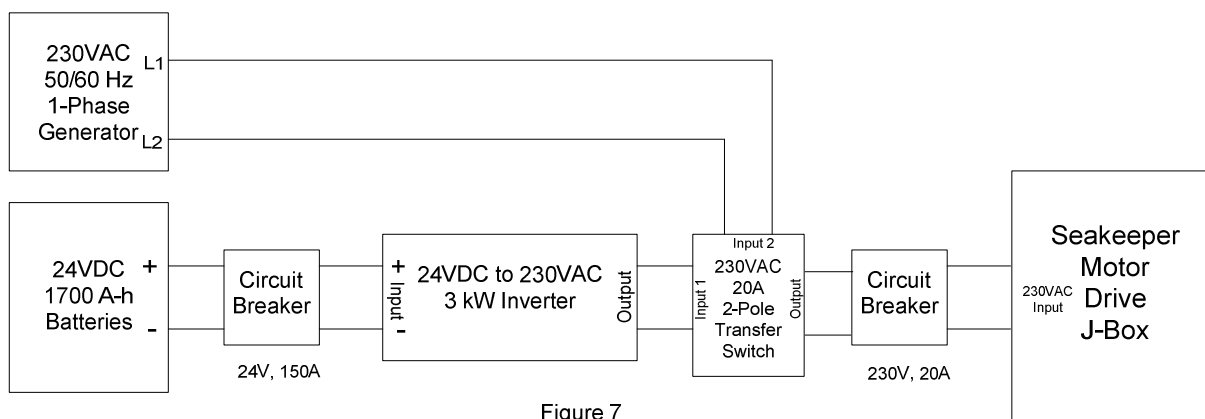

Figure 7  
Installation for Operating from a 24V Battery Bank

*Important Note: This bulletin provides guidance on potential configurations for powering the Seakeeper Model 7000 Gyro Stabilizer. The information in this bulletin does not replace or supercede any information contained in the Seakeeper Model 7000 Installation Manual (Document # 90020) or any information contained in the installation documentation for the converters, inverters, generators, battery chargers, or battery systems mentioned in this bulletin.*