



# **SEAKEEPER**

## ***INSTALLATION MANUAL***



THIS MANUAL COVERS SEAKEEPER 6 MODELS SERIAL  
NUMBERS 6-0001 THROUGH 6-193-1511.

 <b>SEAKEEPER</b>	<b>INSTALLATION MANUAL</b>	<b>Product:</b>	<b>Document #:</b>	<b>Rev:</b>
		SEAKEEPER 6	90402	1

# **SEAKEEPER 6**

## **INSTALLATION MANUAL**

### **JUNE 2017**

#### **Contents:**

**Section 1 – Mechanical Installation**

**Section 2 – Electrical Installation**

**Section 3 – Cooling Installation**

**Section 4 – Startup**

**Section 5 – Installation Checklist and Required Supplies**



**44425 PECAN COURT, SUITE 151**

**CALIFORNIA, MARYLAND, 20619, U.S.A**

**PHONE: 410-326-1590**

**FAX: 410-326-1199**

**E-MAIL: [customerservice@seakeeper.com](mailto:customerservice@seakeeper.com)**

**Section 1: MECHANICAL INSTALLATION**

## 1.0 Introduction

This document is intended to give details and guidance to a boat builder or equipment installer to install the Seakeeper 6 Stabilization System. The Seakeeper is capable of producing loads up to 17 KN (3820 lbs.) at each of the four mounts and careful consideration should be given to foundation design to insure it is capable of transferring these loads into the hull.

There are two methods of installing the Seakeeper 6:

- 1) Bolt-In Installation
- 2) Saddle Installation

**It is assumed that the installer is familiar with bonding using high strength adhesives or mechanical fasteners to marine structures and has performed structural analysis to assure the structure to which the Seakeeper mounts can properly transfer the loads the Seakeeper creates into the hull structure. If the installer has any doubt about the ability of the structure to transfer the loads to the hull then he should contact a licensed naval architect or marine engineer to do a structural analysis.**

The installer should review the following list of reference drawings to ensure the installation procedure is fully understood.

### Reference Drawings

- 90389 Seakeeper 6 Hardware Scope of Supply**
- 90392 Seakeeper 6 Installation Template Kit**
- 90398 Seakeeper 6 Installation Details – Bolt in Method**
- 90399 Seakeeper 6 Installation Details – Bond in Method**
- 90397 Seakeeper 6 Cooling Water Schematic**
- 90396 Seakeeper 6 Cable Block Diagram**

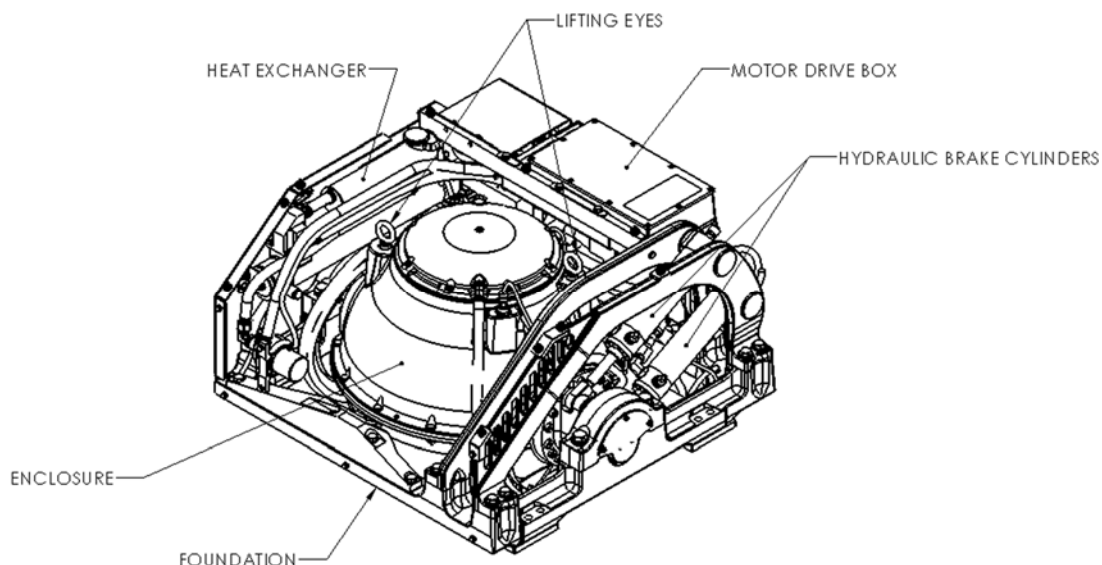

FIGURE 1 – SEAKEEPER 6

**Section 1: MECHANICAL INSTALLATION**

## 1.1 Precautions

- Seakeeper must only be lifted from the supplied lifting eyes (See Section 1.4).
- Seakeeper flywheel is supported by precision bearings. Make certain while unpacking and lifting Seakeeper assembly to NOT drop or impart mechanical shock as damage to bearings could result.
- While handling / installing Seakeeper assembly, protect exposed hydraulic brake cylinder rods (See Figure 1) from scratches or damage as this could lead to premature seal failure and oil leaks.
- While handling / installing Seakeeper assembly, do not allow electrical fittings that exit bottom of Seakeeper enclosure to come in contact with any surface or object as this could damage the fittings and potentially affect the vacuum integrity of the enclosure.
- Exercise care to protect the painted finish as damage to finish could lead to early appearance degradation of installed Seakeeper.

## 1.2 Selection of Installation Location

Selection of mounting location of Seakeeper should consider the following desirable features:



**The Seakeeper must be installed aft of amidships to minimize high acceleration loadings due to hull/wave impacts during operation at high speed or in large waves.**

- **Overhead access or sufficient clearance for removal / re-installation of Seakeeper for overhaul in future years.**
- Seakeeper should be installed in a dry space to minimize effects of corrosion.
- Clearance for replacement of gimbal angle sensor on gimbal shaft (see Figure 2).
- Clearance for filling / purging brake hydraulic oil (see Figure 2).
- Clearance for filling water/glycol cooling circuit (see Figure 2).
- Clearance for replacement of brake hydraulic cylinders (see Figure 2).
- Clearance for routine and regular maintenance including Anode replacement on the Heat Exchanger (see Figure 2).

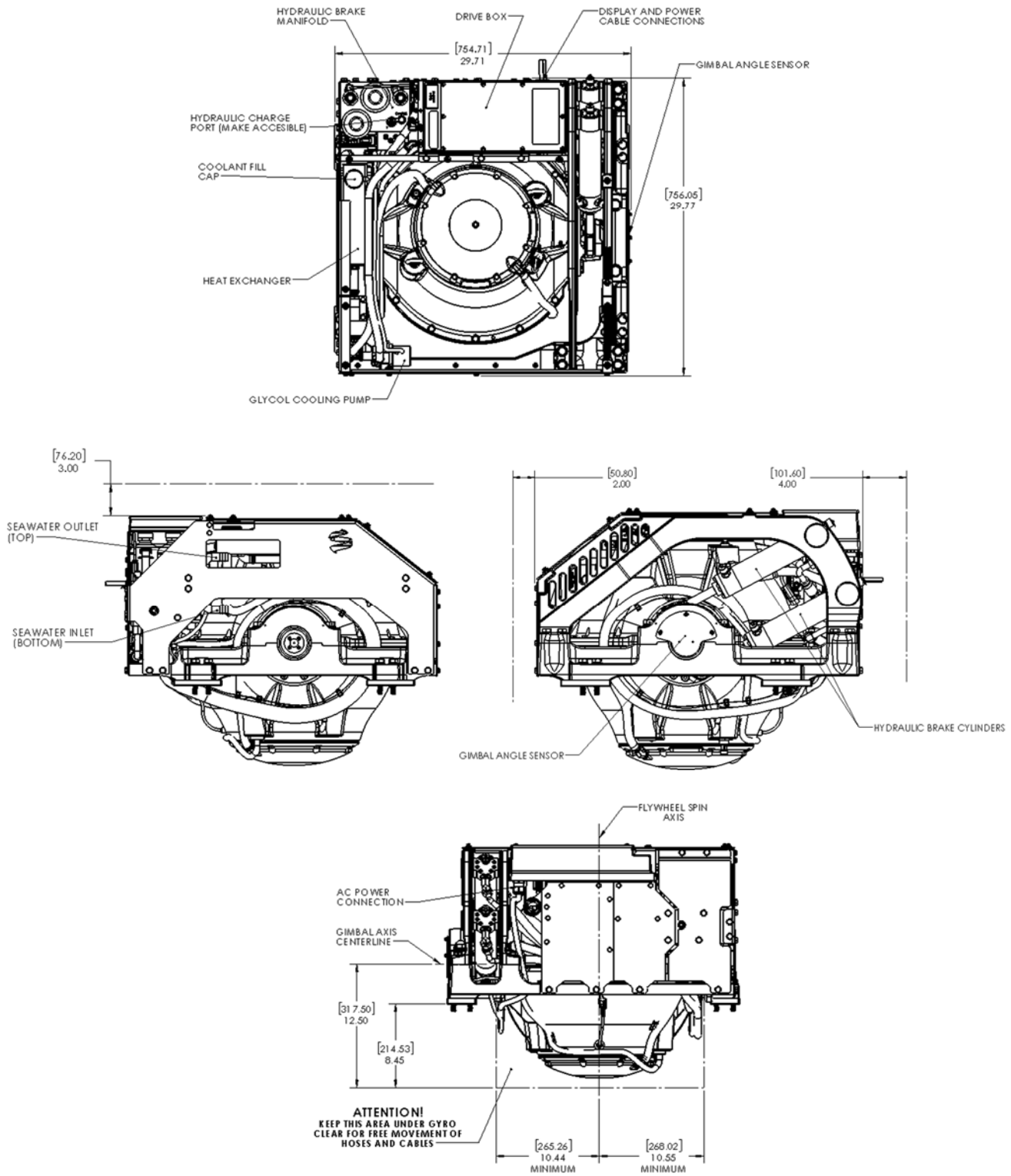
**Section 1: MECHANICAL INSTALLATION**

**VIEWS SHOWING RECOMMENDED CLEARANCES AROUND SEAKEEPER FOR USE OF HAND-TOOLS, EASE OF MAINTENANCE, INSTALLATION AND PROPER OPERATION.**

**FIGURE 2 – INSTALLED SEAKEEPER CLEARANCE CONSIDERATIONS**

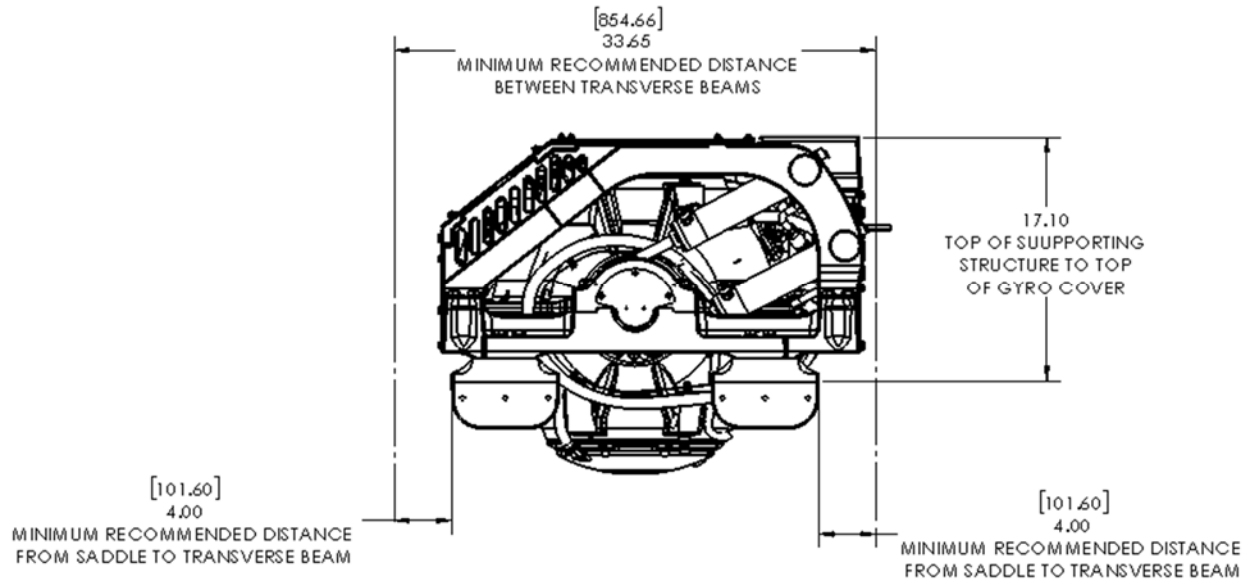
**Section 1: MECHANICAL INSTALLATION**

**FIGURE 3 – TRANSVERSE BEAMS CLEARANCE CONSIDERATIONS**

Refer to Figure 3 for recommended clearances to transverse beams. If a transverse beam is located under the forward brace, it must be 4" (102 mm) from the edge of the saddle beams to provide the necessary clearance for the swing of the motor power cable during precession. Clearances aft of the Seakeeper are shown to provide access for maintenance.

**Section 1: MECHANICAL INSTALLATION**

## Safety



There is a large torque about the gimbal axis when the Seakeeper is precessing. Seakeeper cover panels are provided to prevent personnel or equipment from contacting the Seakeeper while it is in operation. These covers should not be stepped on, or have anything placed on top. The covers should always be in place during operation. If it is ever necessary to access the Seakeeper while the flywheel is spinning, the Seakeeper must be locked at the display to stop the Seakeeper from precessing. Seakeeper maintenance should not be attempted unless the Seakeeper is locked and the flywheel has stopped spinning.

The Seakeeper should be treated with the same respect one gives a high speed rotating propeller shaft or engine shaft.

## Noise/Soundproofing

Seakeeper noise has been measured under steady state conditions (no wave load) in Seakeeper's lab and in our test boat. The steady state noise is typically in the range of 70-75 dB un-weighted. As the frequencies emitting the highest sound pressures are low (like other marine machinery), it is recommended that the Seakeeper be installed in a machinery space that is already treated with soundproofing.

**Section 1: MECHANICAL INSTALLATION**

### 1.3 Selection of Installation Method

The Seakeeper 6 can be affixed to the hull structure using two methods 1) Use bolt-in installation or 2) saddle installation. See figures below.

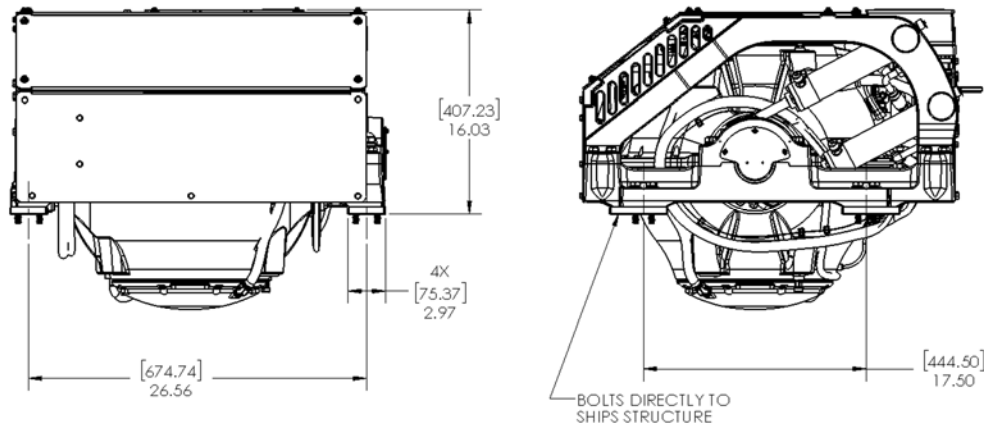

#### OPTION 1- DIRECT FASTENING OF SEAKEEPER FOUNDATION TO SHIPS STRUCTURE

Option 1 would be applied when a metal structure is available for attachment. The foundation would fasten directly to hull structure using isolation gaskets and 16x M12-1.75 fasteners. Depending on the structure to which the Seakeeper is fastened, blind threaded holes or thru-bolting can be utilized.

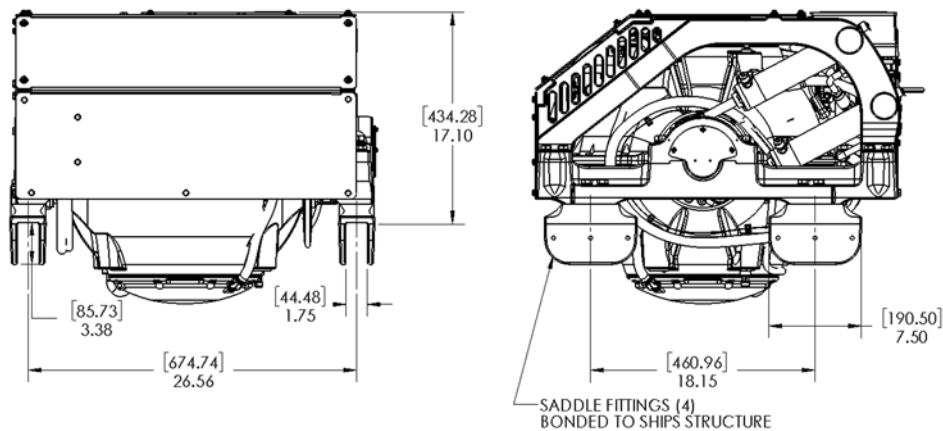

#### OPTION 2- SADDLE INSTALLATION (4 PLACES)

Option 2 would be most commonly used on a hull constructed of glass reinforced plastic (GRP) or fiberglass. For this option, four 7.5 inch (191 mm) long by 3.38 inch (85.7 mm) deep saddles are bonded to properly spaced and prepared structural members that are an integral part of the hull structure. Seakeeper recommends using a structural adhesive with a lap shear strength of 2000 psi (13.8 MPa) or greater. Careful consideration should be exercised by the installer while selecting the appropriate adhesive. Compatibility with the Seakeeper's cast aluminum A356- T6 saddles, hull structure and pot life are three important factors to consider. Proper surface preparation in accordance with adhesive manufacturer's recommendations prior to installation is very important.



**Section 1: MECHANICAL INSTALLATION**

## 1.4 Transport and Unpacking

### 1.4.1 Transport

- 1) Use a Seakeeper provided shipping crate for transport, part number 10977. Overall dimensions of a fully packed crate are 40.25"Lx43"Wx40.25"H with a weight of 870 lbs(395kgs).
- 2) Do not stack Seakeeper shipping crates.
- 3) Both Air and Ground transport are acceptable.
- 4) Seakeeper shipping crates must be transported in environmental conditions between -20°C and 60°C.

### 1.4.2 Unpacking Crate

- 1) Reference Seakeeper Drawing No. 90389, Seakeeper 6 Hardware Scope of Supply for items that ship with the Seakeeper.
- 2) Remove electrical components, cables, and misc. items and set aside.
- 3) Remove packing materials that secure Seakeeper assembly inside the crate.
- 4) Remove top and angled face cover panels to access lifting eyes
- 5) Attach spreader bar to the two lifting eyes located on the top of the Seakeeper enclosure. Stay clear of any other parts on the Seakeeper. Seakeeper 6 weighs 395 kg (870 lbs). See Figure 4 below.

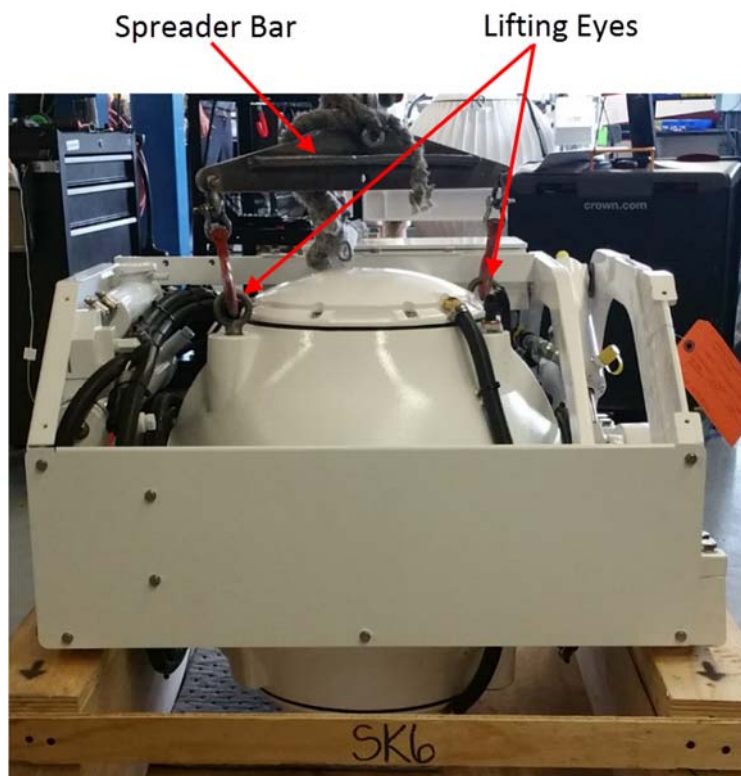

FIGURE 4 – LIFTING ARRANGEMENT

**Section 1: MECHANICAL INSTALLATION**

## 1.5 Bolt-In Installation

### 1.5.1 Check and Preparation of Hull Structure

Refer to Seakeeper **Drawing No. 90398, Seakeeper 6 Installation Details – Bolt in Method**. Important dimensional and load information is given in this drawing that will impact the design details of the structure that will receive the Seakeeper. It is assumed that a proper structural analysis has been performed for the hull structure to which the Seakeeper will be fastened to insure proper strength margins for the loads the Seakeeper will create during operation.

The hull structure supporting the Seakeeper should be installed so the Seakeeper is parallel to the waterline. **In addition, the four areas on top of the beams on which the feet of the Seakeeper foundation and isolation gaskets will rest need to be co-planar within .06" (1.5 mm) to minimize potential distortion of Seakeeper support frame when installed.**

Seakeeper provides an installation template kit, P/N 90392, which contains four plates that mimic the mating surfaces of the four feet located on the Seakeeper's foundation. These plates have 4 holes located at the same centers as the mounting holes on the Seakeeper. The fixture locates the hole patterns at the proper spacing both in the fore-aft direction and the port-starboard direction. See Figures 5 below. Once assembled, the fixture can be used to check clearances and alignment of the hull structure.

**Note: Do NOT use the installation fixture to establish Seakeeper envelope dimensions. Refer to Drawing No. 90398 for envelope dimensions. A 3-D model of the Seakeeper is available on the Seakeeper website ([www.seakeeper.com](http://www.seakeeper.com)) to aid in designing the Seakeeper foundation and the space around the Seakeeper.**

**NOTE: MAKE SURE NO OBSTRUCTIONS FROM THE HULL STRUCTURE CAN BE SEEN WITHIN THE INSIDE OF THE INSTALLATION TEMPLATE KIT (INSIDE THE MARKED RED LINES). SEE SECTION 1, PAGE 9 OF INSTALLATION MANUAL.**

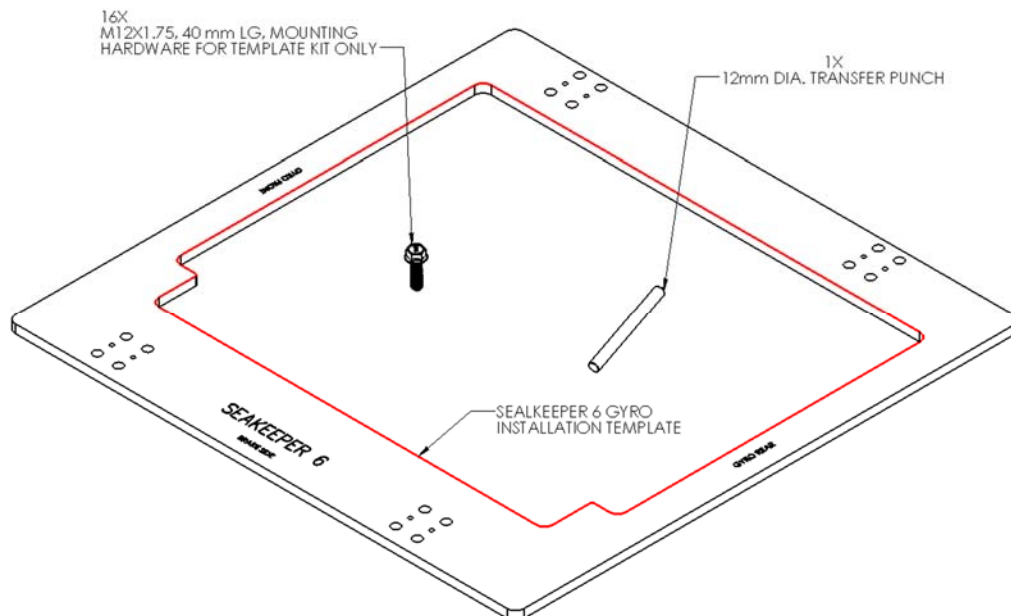
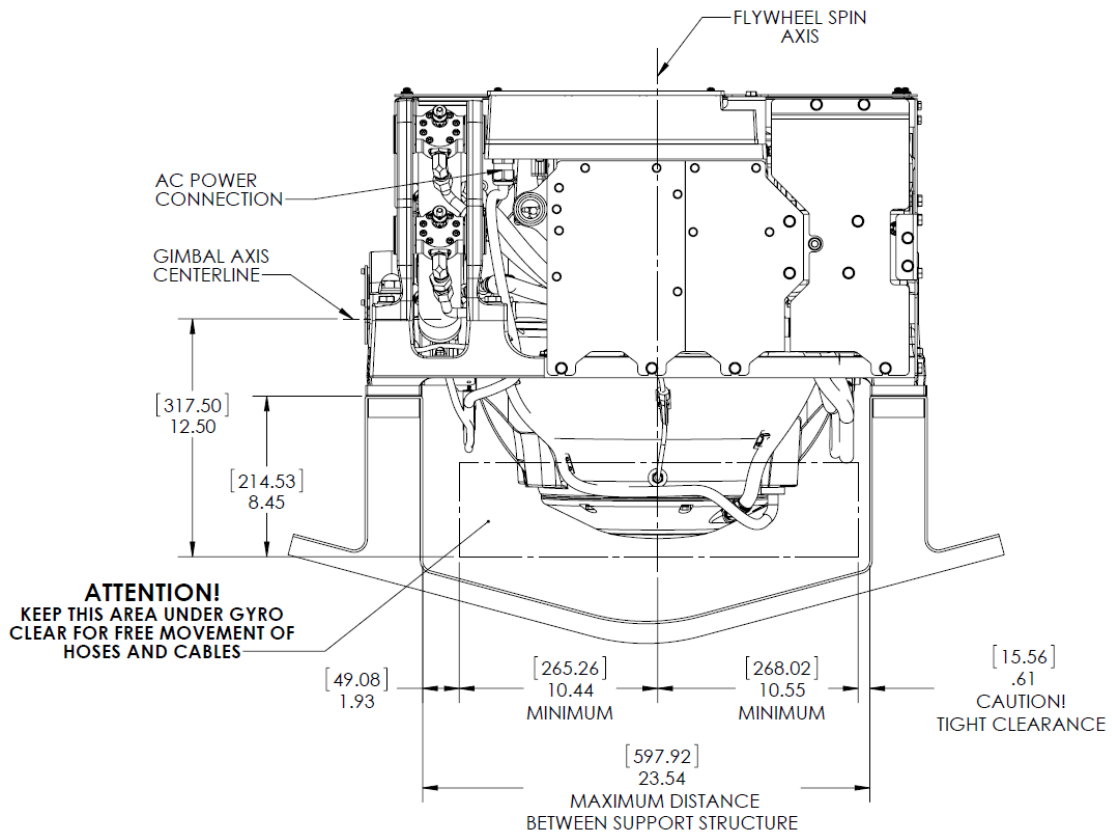
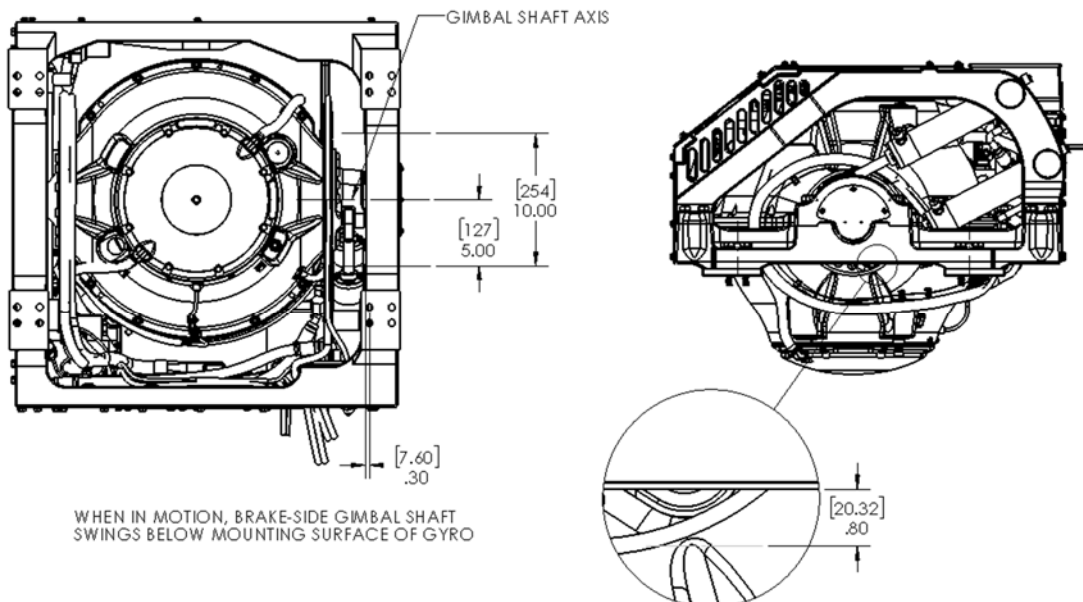

FIGURE 5 –INSTALLATION TEMPLATE KIT, P/N: 90392

**Section 1: MECHANICAL INSTALLATION**



**CAUTION: Tight clearances from cable guide bands and brake side gimbal shaft to hull structure. See below for brake side gimbal shaft clearance. See above figure for dimensions and reference Seakeeper drawing NO. 90398 for complete Seakeeper envelope.**



**Section 1: MECHANICAL INSTALLATION**

## 1.5.2 Transfer of Holes to Boat Structure

- 1) Lower assembled fixture onto hull structure.
- 2) **The four areas where the feet of the Seakeeper will rest should be coplanar to within .06" (1.5mm). See Figure 9.**
- 3) Align fixture in desired location and transfer holes from fixture plate to the foundation structure. Note that holes in fixture plate are  $\varnothing 0.487$ " (12 mm). A transfer punch is supplied with installation template kit, P/N 90392.
- 4) Remove fixture and drill and tap M12X1.75 holes in foundation at marked locations to mate with holes in the foundation. Take special care to drill perpendicular to mounting surface. Remove any impeding obstructions.

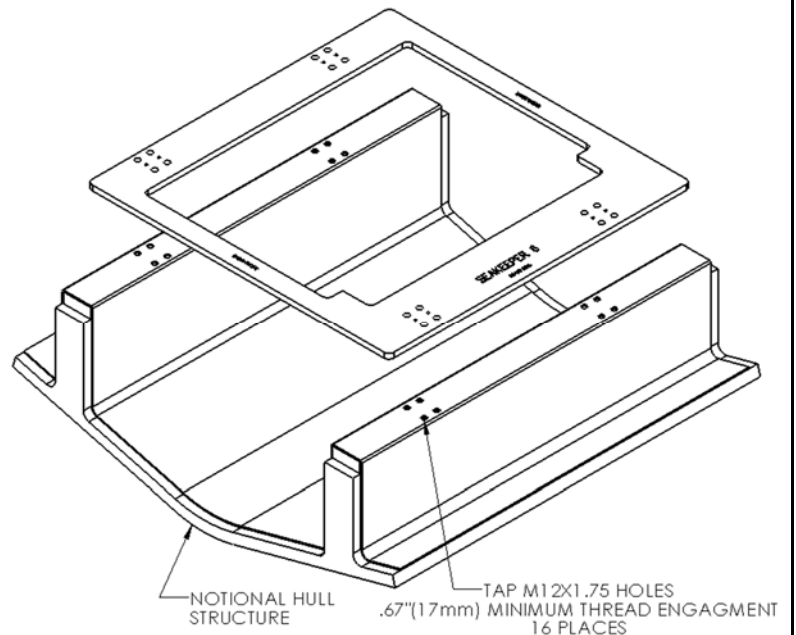
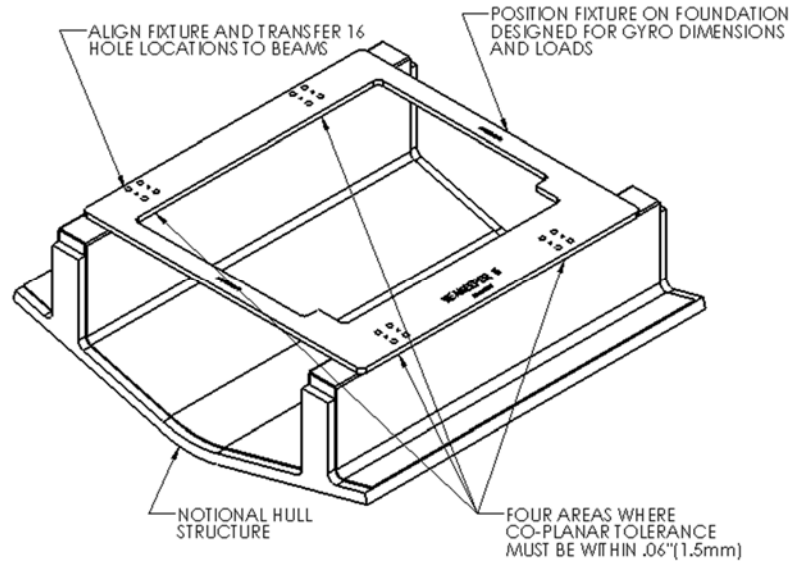

**Section 1: MECHANICAL INSTALLATION**

### 1.5.3 Installation of Seakeeper

- 1) Locate and position 4 foundation spacers, and 4 isolation gaskets onto hull structure. **NOTE:** Sealant or caulk is recommended to be applied. Apply a small bead (approximately 4mm wide) of sealant (silicone or caulk) between all mating surfaces of each foundation spacer and each isolation gasket. This will prevent water from wicking between the parts and setting up corrosion. Check foundation spacers and isolation gasket alignment by test fitting bolts without any obstructions.
- 2) Lower Seakeeper into position onto foundation beams and align over drilled holes.
- 3) Install Seakeeper supplied M12X1.75 – 70mm fasteners– **apply a moderate coat of removable thread locker to the threads** of each bolt and include a small bead of marine sealant under each washer before installation.
- 4) **Torque all fasteners to 65 ft-lbs (88 N-m).**
- 5) Proceed to electrical and cooling portion of the installation.

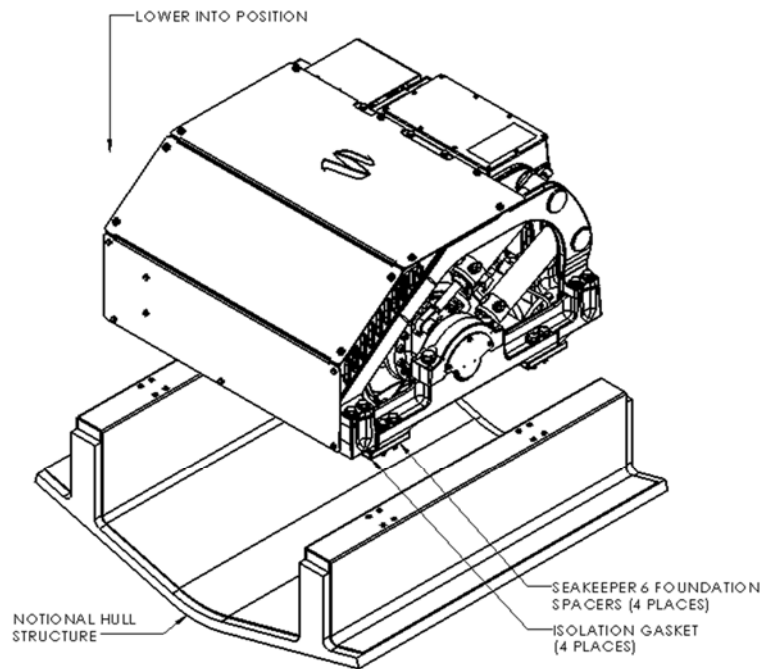

**NOTE:** SEAKEEPER 6 FOUNDATION SPACERS TO BE INSTALLED BETWEEN GYRO AND ISOLATION GASKET. ISOLATION GASKET TO BE INSTALLED BETWEEN FOUNDATION SPACER AND NOTIONAL HULL STRUCTURE. SEE DETAIL VIEW.

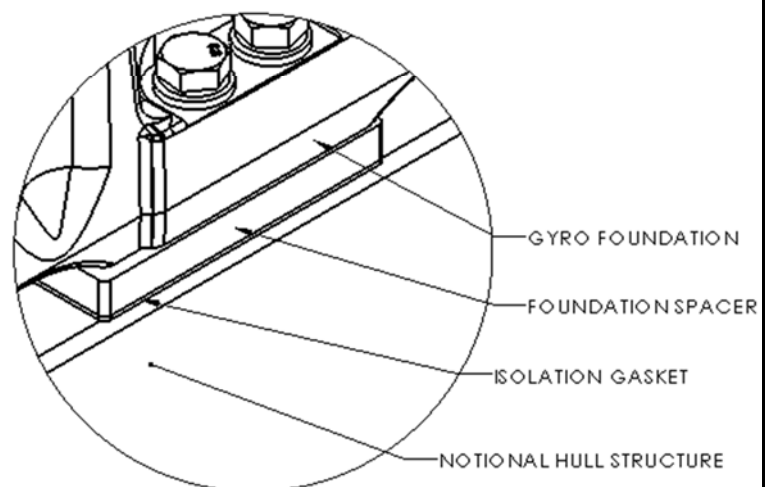

**Section 1: MECHANICAL INSTALLATION**

## 1.6 Saddle Installation

Seakeeper recommends Plexus MA590 adhesive for bonding the saddles to the GRP hull structure. Plexus MA590 is a two-part methacrylate structural adhesive that has characteristics conducive to this type of installation. Details of the bonding procedure in this manual will involve the Plexus MA590 product, but that should not exclude other suitable adhesives the installer chooses to use. **See Sheet 5 of Seakeeper drawing no. 90399 for loads information and recommended adhesive properties.**

### 1.6.1 Initial Check and Preparation of Hull Structure

Refer to Seakeeper **Drawing No. 90399, Seakeeper 6 Installation Details – Bond In Method.** Important dimensional and load information is given in this drawing that will impact the design details of the structure that will receive the Seakeeper as well as selection of the adhesive to bond the Seakeeper into the hull.

The foundation “saddles” of the Seakeeper are designed to be bonded directly to the composite hull structure of the vessel to effectively distribute gyroscopic loads. **A complete bond is required between the inside surface of the saddles and the hull structure.** Seakeeper recommends having a minimum of 7 cartridges (225mL), 1 bottle Plexus PC-120 Primer/Conditioner, and 2 manual adhesive guns on hand for installation. Two workers should apply the adhesive at the same time to finish the installation before the adhesive starts to cure. To aid in determining the quantity of adhesive required, the interior surface area (bonding surfaces) of **each** saddle is 58.2 in<sup>2</sup> (375 cm<sup>2</sup>) for a total bonded surface area for all four saddles of 232.5 in<sup>2</sup> (1500 cm<sup>2</sup>).

The hull structure supporting the Seakeeper should be installed so the Seakeeper is parallel to the waterline. **The four areas on top of the beams that the saddles will bond to need to be co-planar within .13” inches (3 mm) for consistent adhesive bond gap. In addition, the four areas on top of the saddles on which the feet of the Seakeeper foundation will rest need to be co-planar within .06” (1.5 mm) to minimize potential distortion of Seakeeper support frame when installed.**

**Note that any paint or gel-coat present in bond area should be removed so that adhesive will bond directly to laminate fibers and resin.**

Seakeeper provides an installation fixture template, P/N 90392 that locates the saddles at the proper spacing both in the fore-aft direction and the port-starboard direction. See Figures 6, 7 & 8 below. Once assembled with the provided saddle fittings, the fixture can be used to check saddle clearances and alignment of the hull structure. The fixture will allow the builder / installer to lay-up and adjust the foundation dimensions to create a low-clearance fit between the Seakeeper foundation saddles and the hull structure. Shear strength of the adhesive will be maximized if the cured thickness between the vessel structure and Seakeeper saddles is at the thinner end of the adhesive manufacturer’s recommended range. Therefore, the fixture should be used to confirm

**Section 1: MECHANICAL INSTALLATION**

that the overall dimensions of the foundations are square and level and that the adhesive gap is within Seakeeper's maximum recommended thickness of .13" or 3mm.

**Note: Do NOT use the installation fixture to establish Seakeeper envelope dimensions. Refer to Drawing No. 90399 for envelope dimensions. A 3-D model of the Seakeeper is available on the Seakeeper website ([www.seakeeper.com](http://www.seakeeper.com)) to aid in designing the Seakeeper foundation and the space around the Seakeeper.**

**NOTE: MAKE SURE NO OBSTRUCTIONS FROM THE HULL STRUCTURE CAN BE SEEN WITHIN THE INSIDE OF THE INSTALLATION TEMPLATE KIT (INSIDE THE MARKED RED LINES). SEE DRAWING NO. 90399.**

M12-1.75 X 40 mm LONG HEX HEAD FLANGE SCREW  
(16 PLACES)

THESE CAP SCREW SHOULD BE USED TO ATTACH THW INSTALLATION TEMPLATE (90362) TO EITHER THE INSERT PLATE OR SADDLE TYPE FOUNDATIONS FOR ALIGNMENT AND INSTLLATION ASSISTANCE OF THESE FOUNDATIONS ONLY. THEY SHOULD NOT BE USED IN THE ACTUAL INSTALLMENT OF THE GYRO MOUNTING

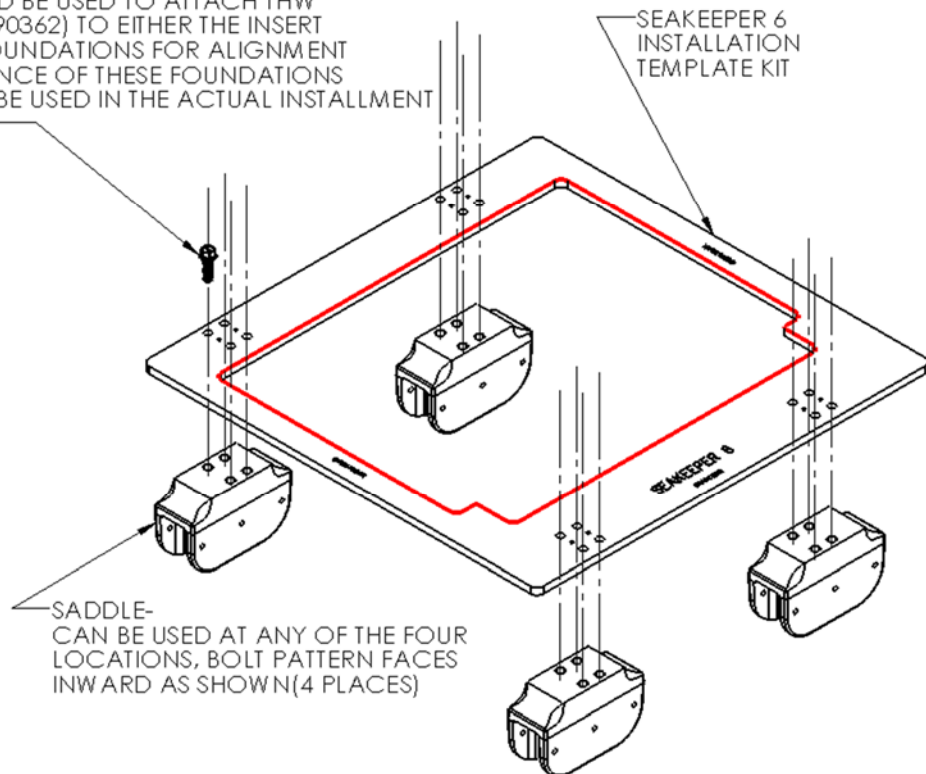

**FIGURE 6 – EXPLODED VIEW OF SADDLE INSTALLATION FIXTURE**

**Section 1: MECHANICAL INSTALLATION**

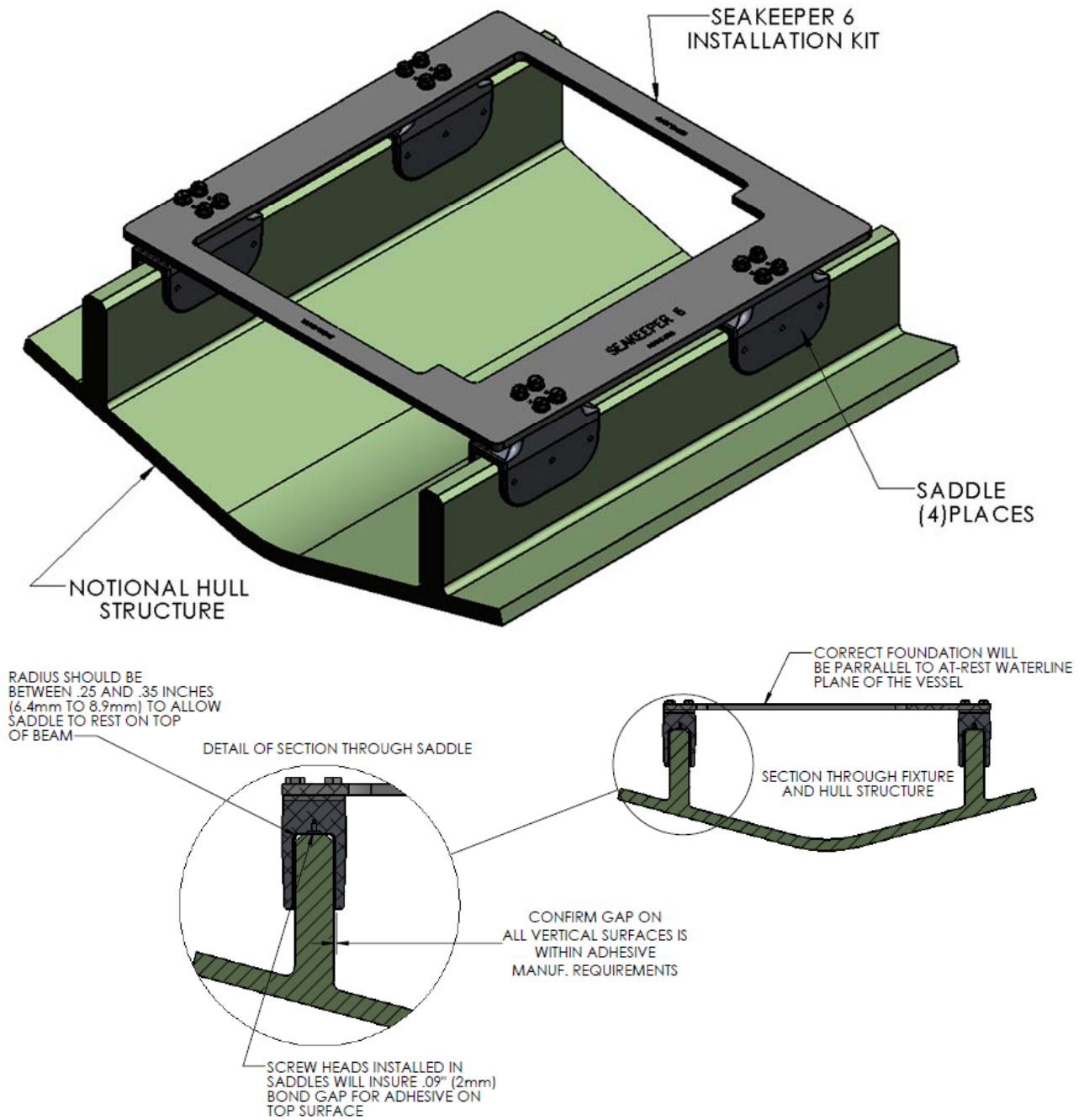

**FIGURE 7 – SADDLE INSTALLATION FIXTURE ON NOTIONAL HULL STRUCTURE**



**Section 1: MECHANICAL INSTALLATION**

## 1.6.2 Fiberglass Hull Preparation

- 1) Position installation fixture (Fig 8) on hull girders noting recommended clearances for maintenance from Figure 2. Check that the screws fastening the saddles to the installation fixture are tight (Fig 6).

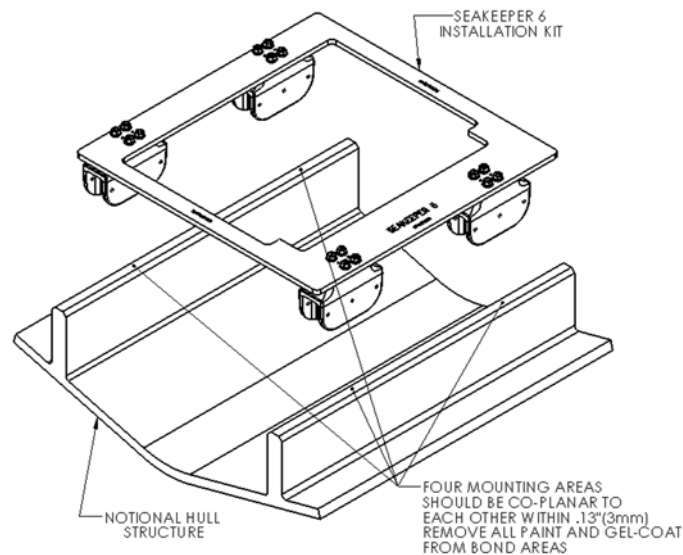

FIGURE 8 - INSTALLING FIXTURE ON HULL

- 2) Mask hull area (Fig 9) around foundation saddles for easy clean-up and to create outline of surface area to receive adhesive as (Fig 8). Insure that the bond gap is within Seakeeper's recommended thickness, or 3mm if using Plexus MA590.

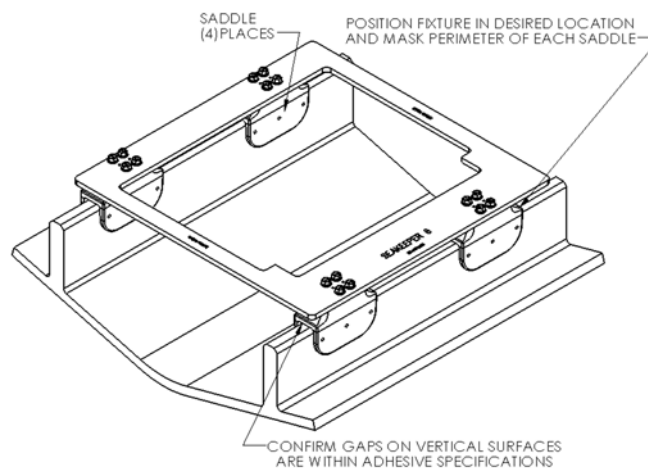

FIGURE 9 - MASKING PERIMETER OF SADDLES

- 3) Raise fixture clear of foundation. Check all four mounting areas are co-planar to within .13" (3 mm) to each other, as well as parallel to the water line plane, as shown in Fig 8.

**Section 1: MECHANICAL INSTALLATION**

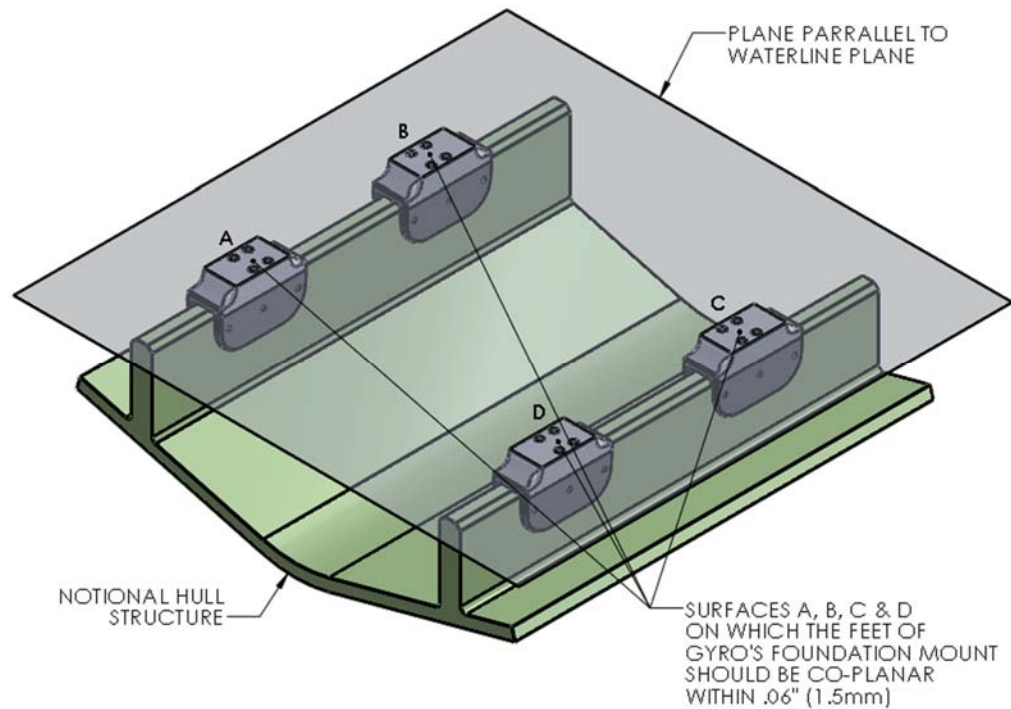

FIGURE 10 – COPLANAR PROPERTIES OF FOUNDATION

- 4) Thoroughly clean with alcohol or acetone all areas of girders to be bonded to remove any contaminants. Use new paper towels for cleaning, not shop rags.
- 5) Remove any paint or gel-coat from bond surfaces so that adhesive will bond directly to laminate fibers and resin as shown in Figure 8.
- 6) **Thoroughly sand girder bond surfaces with 80 grit sandpaper. (IMPORTANT – BOND STRENGTH MAY BE REDUCED IF THIS STEP IS SKIPPED.)**
- 7) Wipe surfaces clean from dust with alcohol or acetone using new paper towels, not shop rags.
- 8) Re-position installation fixture on girders and double-check that the adhesive gap is within the adhesive manufacturer's maximum recommended thickness. Seakeeper recommends a maximum gap of 3mm if using Plexus MA590.

**Note if bonding saddles to a metal structure, contact Seakeeper for hull preparation instructions.**

**Section 1: MECHANICAL INSTALLATION**

### 1.6.3 Seakeeper Saddle Preparation

- 1) Ensure that screws fastening saddles to the installation fixture are tight (Fig 6).
- 2) Check that each saddle contains 2 plastic screws which will insure an adhesive gap of .080" (2 mm) on top surface of hull as shown in Figure 11.
- 3) Thoroughly clean with alcohol or acetone the inside surfaces of Seakeeper foundation saddles to remove any contaminants as shown in Figure 11. Use new paper towels for cleaning, not shop rags.

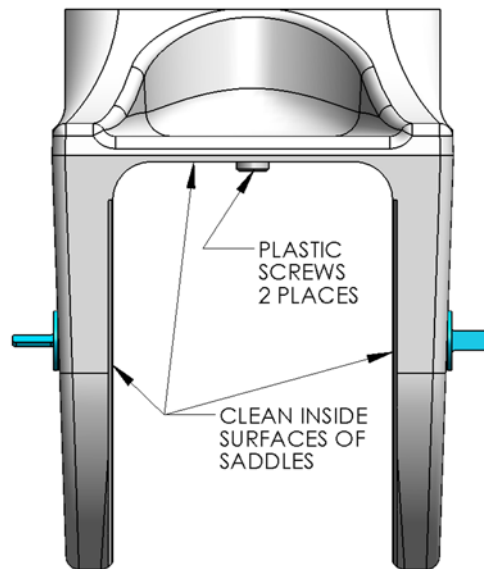

FIGURE 11 - SADDLE CLEANING

- 4) **Thoroughly sand all saddle inside surfaces with 80 grit sandpaper. (IMPORTANT – BOND STRENGTH MAY BE REDUCED IF THIS STEP IS SKIPPED.)**
- 5) Wipe surfaces clean from dust with alcohol or acetone using new paper towels, not shop rags.
- 6) If using Plexus MA590 adhesive, apply Plexus PC-120 surface conditioner to inside surfaces of Seakeeper foundation saddles in accordance with manufacturer instructions. These instructions are located at the end of this section. If using an alternate adhesive, check with manufacturer if any surface conditioner/etch is required for the aluminum saddles.

**Section 1: MECHANICAL INSTALLATION**

### 1.6.4 Bonding Saddles to Hull

Note: If using Plexus MA590 adhesive, the Seakeeper saddles should be installed when PC-120 is confirmed dry.

- 1) Assemble Plexus cartridge into either the manual or pneumatic gun as shown. Remove cap on cartridge and attach mixing tip. For pneumatic gun, start with low air pressure and increase until desired flow rate is achieved.

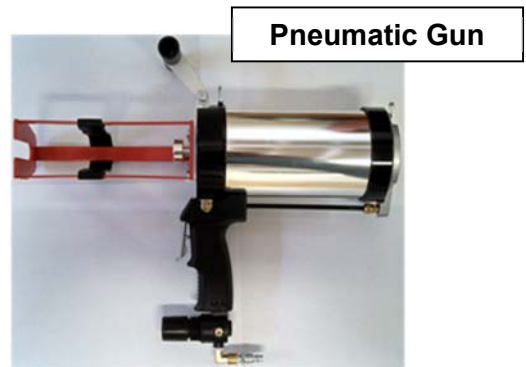
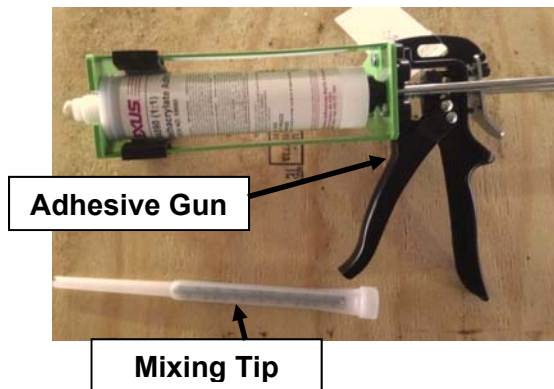

- 2) Cut tip of mixing wand as shown in photo.

- 3) Prepare a second mixing wand as shown in photo below by attaching the simple flexible nozzle to the end of the mixing tip. Set aside for now as this will be used to inject adhesive into the sides of each saddle after the fixture / saddles are in position.



- 4) Install provided rubber plugs in six holes of each saddle. The plugs will limit the adhesive being forced out of the injection holes in step 6 below.

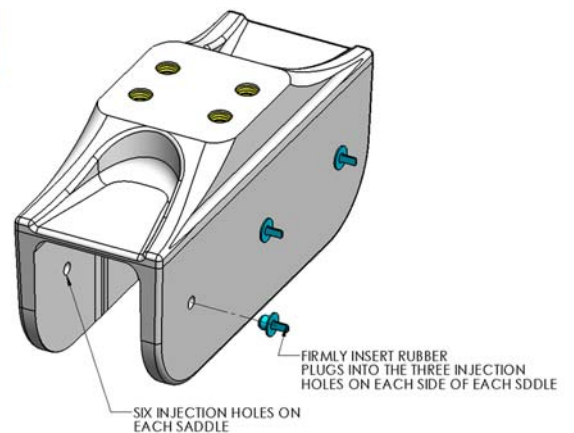

**Section 1: MECHANICAL INSTALLATION**

5) Apply large bead of Plexus adhesive to the hull structure as shown in the figure to the right. Apply approximately 1/2 to 2/3rds cartridges at each of the four locations. **Work deliberate and fast as it takes some time to apply the adhesive to the structure. MA590 has a 90 minute working time at room temperature (23°C / 73°F). This working time can reduce to 40-50 minutes at elevated temperatures. Two workers should apply the adhesive at the same time to finish the installation before the adhesive starts to cure.**

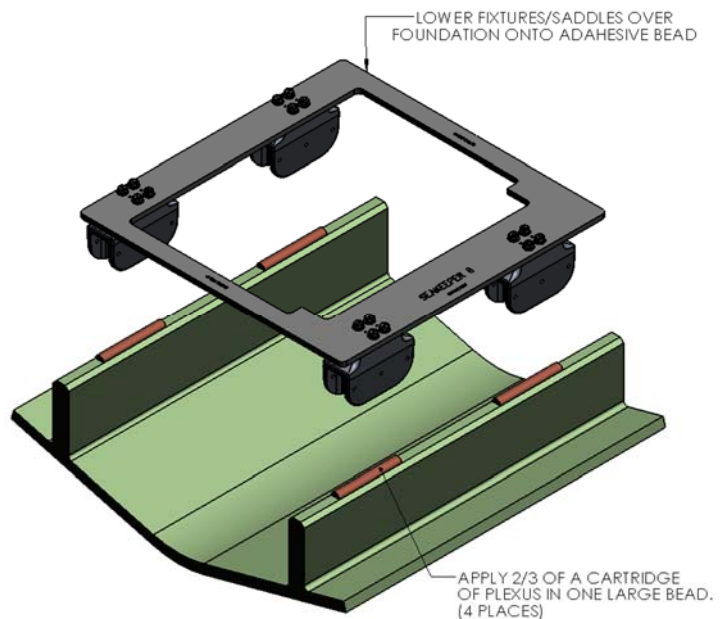

6) Lower fixture and saddles over the hull structure and apply light downward pressure to each of the four saddles until the two nylon screws rest on the hull structure (SEE FIG. 7). The adhesive will be forced towards the forward and aft ends of each saddle and partially down the sides of the foundation beams.

7) Insert full adhesive cartridge along with mixing wand / nozzle assembled in step 3 above into gun.

8) Begin to inject adhesive into the six holes provided on each side of each of the four saddles. Follow the numbered sequence shown until the adhesive pushes out the edges of the saddle perimeter. The intent is to pump in the adhesive working from the top down and from the middle to the ends to fill the gaps and displace any air.

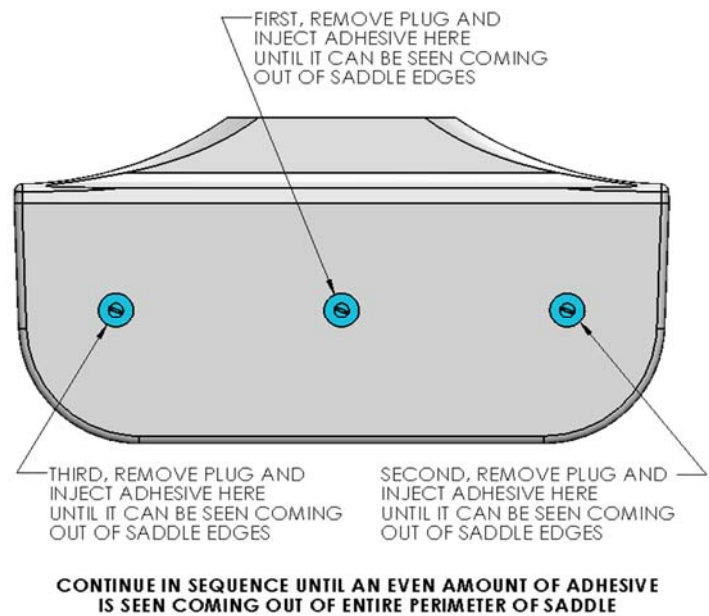

**A complete bond is required – excess adhesive will be needed to make sure all bond gaps are filled.**

**Section 1: MECHANICAL INSTALLATION**

- 9) Repeat above step for remaining 7 sides of the saddles.
- 10) When gaps have been completely filled, clean off excess adhesive, remove plugs, and remove masking tape.
- 11) **Allow adhesive to cure per manufacturer's recommendations. Follow adhesive guidelines for curing time versus temperature prior to removing the fixture.**
- 12) Bonding of Seakeeper saddles onto the hull is now complete. Remove installation fixture.

### 1.6.5 Installation of Seakeeper

- 1) **The four areas where the feet of the Seakeeper will rest should be coplanar to within .06" (1.5mm). See Figure 10.**

- 2) Rig Seakeeper for lifting and lower into position onto top surface of four saddles.

- 3) Apply a small bead (approximately 4mm wide) of sealant or caulk to the mating surfaces between the saddles and the Seakeeper foundation. Adjust position of Seakeeper until alignment is achieved for the 16 fasteners that will attach Seakeeper foundation frame to saddles.

- 4) Install Seakeeper supplied M12X1.75 – 70mm fasteners— **apply a moderate coat of removable thread locker to the threads** of each bolt and include a small bead of sealant under each washer before installation.

- 5) **Torque all fasteners to 65 ft-lbs (88 N-m).**

- 6) Proceed to electrical and cooling portion of the installation.

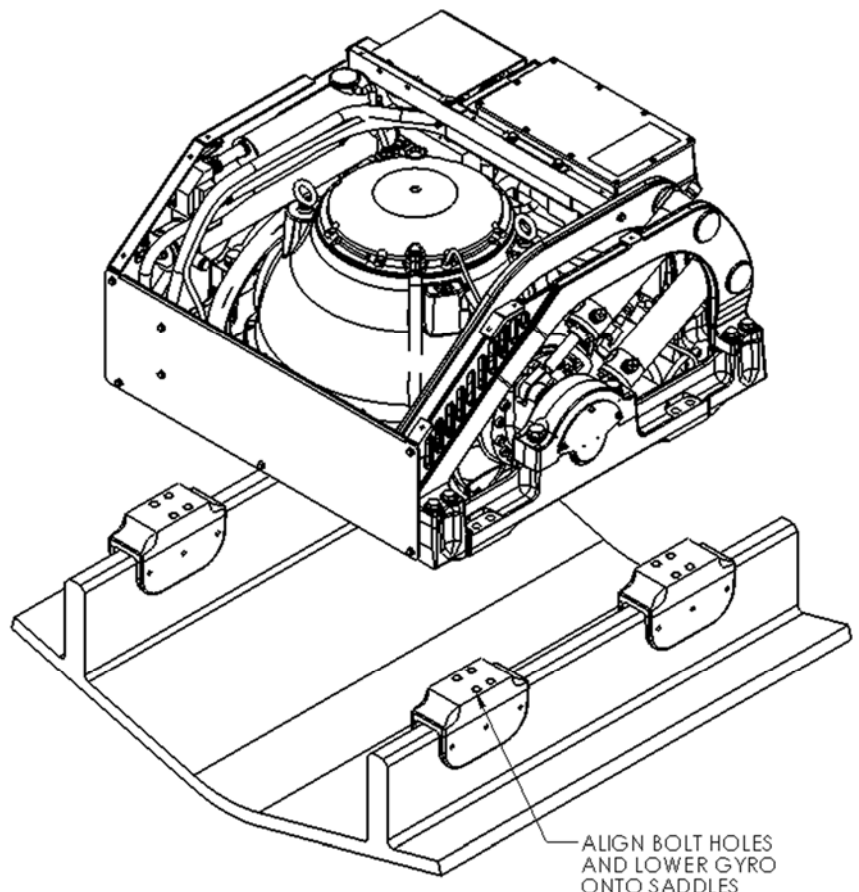

NOTE:  
CHECK FOUR MOUNTING AREAS  
ON SADDLES ARE CO-PLANAR  
WITHIN .06" (1.5mm). SEE FIGURE 10

**Section 1: MECHANICAL INSTALLATION**

## **1.7 Removal and Disposal**

### **1.7.1 Removal**

This section details basic instructions for removal of a Seakeeper from a boat. The overall basic instructions are to reverse the installation instructions:

- 1) Disconnect seawater pump from heat exchanger and power connector on wiring harness.
- 2) Drain heat exchanger of all seawater.
- 3) Disconnect both Seakeeper input power cables.
- 4) Remove all installation fasteners.
- 5) Remove the Seakeeper unit using a spreader bar.

### **1.7.2 Disposal**

DO NOT disassemble the Seakeeper to a greater degree than necessary for removal from the boat. DO NOT dispose of a Seakeeper unit in a landfill. The unit must be shipped back to Seakeeper.

**Section 2: ELECTRICAL INSTALLATION**

## 2.0 Introduction

This section for electrical installation explains how to mount the electrical equipment and how to connect the electrical cables.

### Reference Documents & Drawings

**90389 Seakeeper 6 Hardware Scope of Supply**  
**90403 Seakeeper 6 Operation Manual**

**90396 Seakeeper 6 Cable Block Diagram**  
**90438 Touchscreen Display Envelope and Mounting Details**

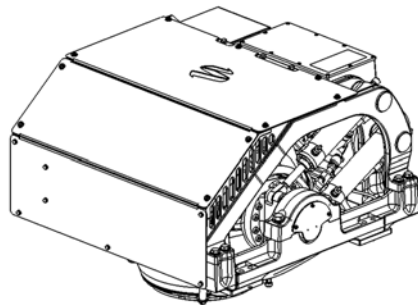

Seakeeper 6, Front Oblique View

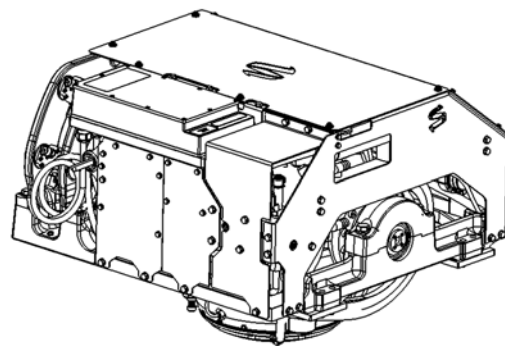

Seakeeper 6, Rear Oblique View



12VDC Power Connector



Terminator, Female



Tee Adapter



Touch Screen Display



USB Extension Cable



2ft Cable



25m Cable

FIGURE 1 – ELECTRICAL EQUIPMENT FOR SEAKEEPER 6



**Section 2: ELECTRICAL INSTALLATION**

## 2.1 Electrical Equipment Mounting

### Precautions

- Each item of electrical equipment has specific mounting instructions. These instructions should be followed to insure proper function of the Seakeeper 6.



**Do NOT move Seakeeper mounted components from their locations or incorrect Seakeeper operation will result.**

#### 1. TOUCH DISPLAY MOUNTING INSTRUCTIONS, SURFACE MOUNT

- a. Console space required: Approx. 5.24 W x 3.70 H inches (133 x 94 mm)
- b. Mounting Instructions, Surface Mount: See drawing 90438 for details

#### 2. CAN COMMUNICATIONS TEE ADAPTER AND TERMINATOR MOUNTING INSTRUCTIONS

- a. Console space required, Rear: Approx. 4 W x 3 H inches (102 x 76 mm)
- b. Mounting Instructions: Rear mount on vessel console panel, within 1 ft (0.3m) of Display.
- c. Hardware required: One mounting screw for .197" (5 mm) diameter mounting hole on Tee Adapter.

#### 3. USB EXTENSION CABLE ASSEMBLY MOUNTING INSTRUCTIONS

- a. Console space required: Approx. 2 W x 2 H inches (51 x 51 mm), within 6 ft (2 m) from Touch Display.
- b. Mounting Instructions, Surface Mount: Use panel cutout as shown in section 2.5. Maximum panel thickness 1/8" (3.2 mm)
- c. Install sealed USB connector end of the extender cable assembly in panel from rear and secure with hex jam nut (provided) on front.
- d. Connect M12 connector end of the extender cable assembly to the rear of the Touch Display on receptacle AUX.

**Section 2: ELECTRICAL INSTALLATION**

## 2.2 Electrical Equipment Power Connections

### 1. AC INPUT POWER SOURCE REQUIREMENTS

- a. Either of two AC input voltages are acceptable:
  - i. 110 VAC (nominal), 1 Phase, 50/60 Hz, 25 Amps.
  - ii. 230 VAC (nominal), 1 Phase, 50/60 Hz, 20 Amps.
- b. A separate circuit breaker should be used for each Seakeeper Drive Box.
- c. Seawater pumps must be rated at 110 or 230 VAC, consistent with the AC input voltage used, and must be 5 Amps max.

### 2. DRIVE BOX AC POWER INPUT CONNECTION INSTRUCTIONS

- a. Cable: 3 x 10AWG (3 x 6mm<sup>2</sup> CSA), 10' (3m) length, Seakeeper supplied pre-installed.
  - i. Locate CABLE 2 for AC power input to the Drive Box at the outward of three cable glands.

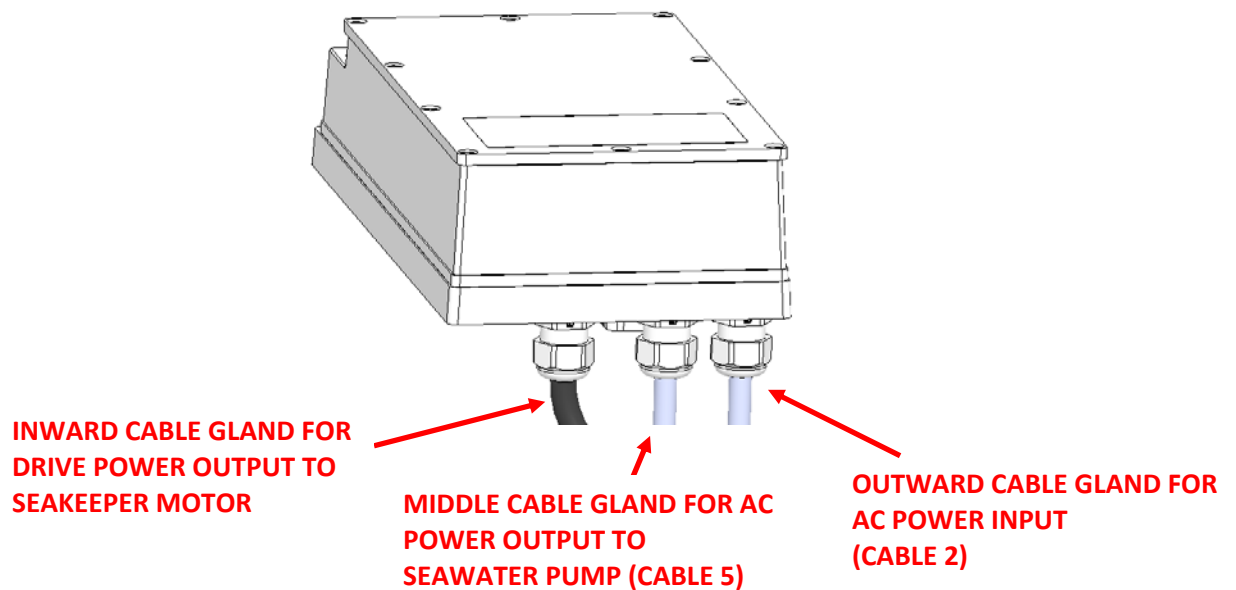

FIGURE 2 – DRIVE BOX AC POWER INPUT & OUTPUT CABLE GLANDS

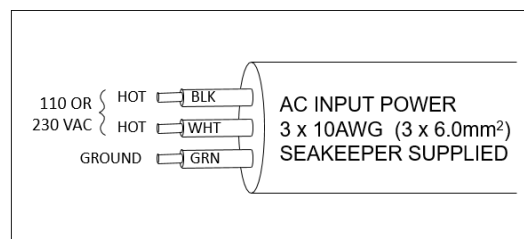

FIGURE 3 – CABLE 2 WIRE CONNECTIONS AT AC POWER DISTRIBUTION PANEL

**Section 2: ELECTRICAL INSTALLATION**

- ii. Connect AC input conductors in CABLE 2 to a double-pole Circuit Breaker at an AC power distribution panel according to Figure 3 above.
  - 1. 110 VAC, 25 Amp circuit breaker
  - 2. 230 VAC, 20 Amp circuit breaker

**3. DRIVE BOX AC POWER OUTPUT TO SEAWATER PUMP CONNECTION INSTRUCTIONS**

**Verify that AC power is OFF to the Drive Box before connecting CABLE 5 to a Seawater Pump.**

- a. Locate CABLE 5 for AC power output to the Seawater Pump from the Drive Box at the middle of three cable glands. (See Figure 2.)

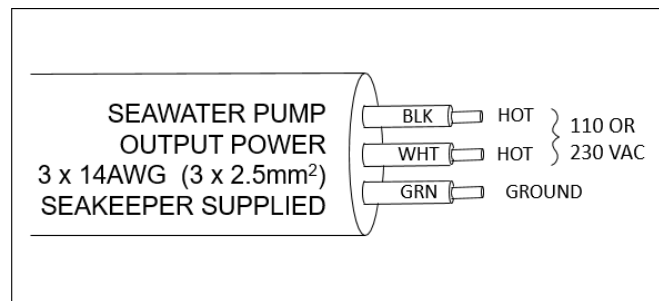

FIGURE 4 – CABLE 5, AC OUTPUT POWER CABLE

- b. Connect the AC output conductors in CABLE 5 to a 5 Amp maximum, Seawater Pump according to Figures 4 and 5.
  - i. Pumps must be rated at 110 or 230 VAC, 5 Amps max., Customer-supplied.
  - ii. The customer supplied seawater pump must have overcurrent protection with a rating of 5A, 250 VAC. This protection circuit shall be installed in line with the seawater pump as shown in the diagram below.

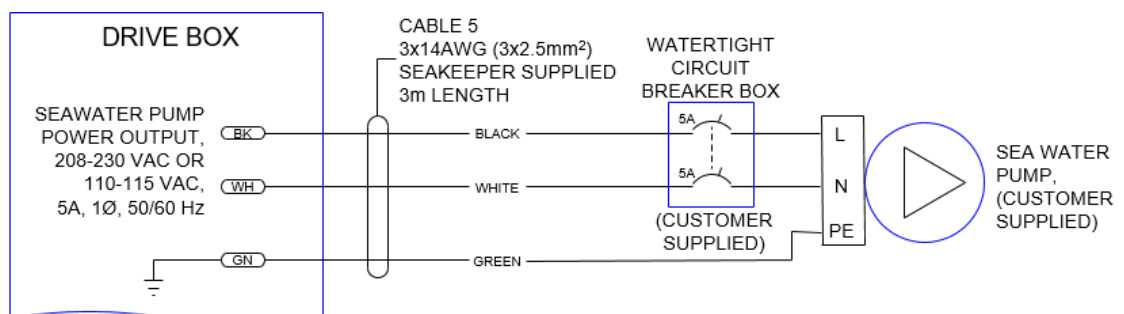
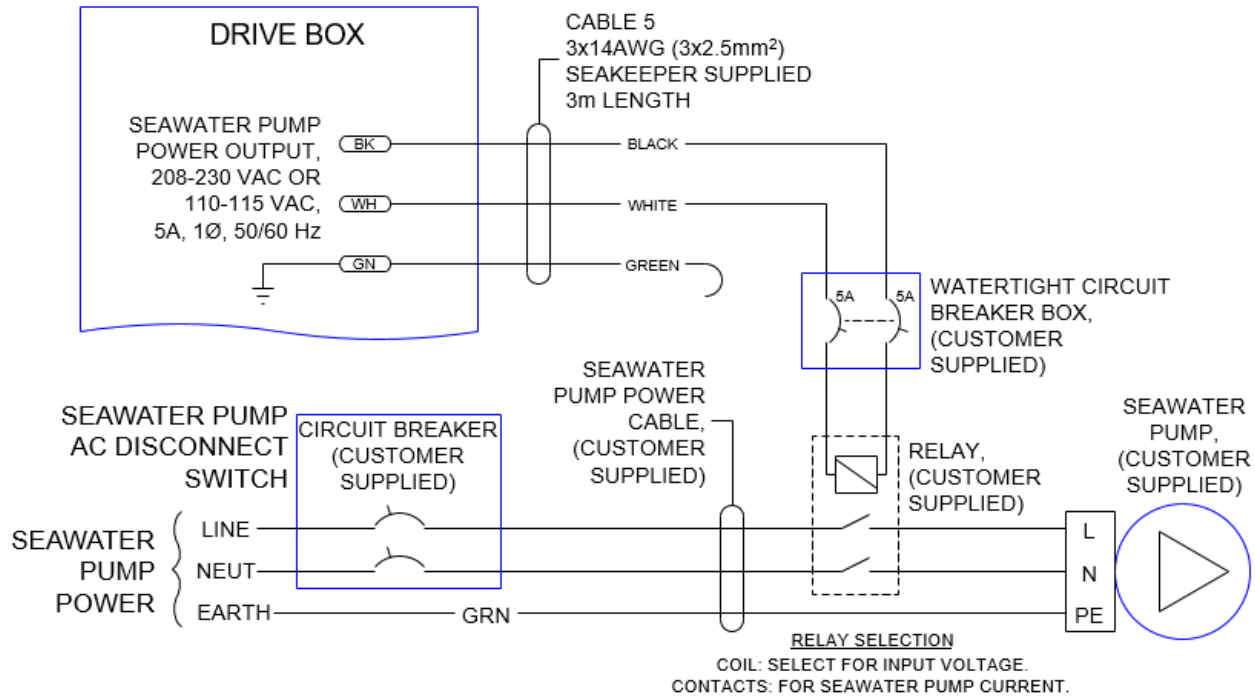

FIGURE 5 – CABLE 5, WIRE CONNECTIONS TO SEAWATER PUMP

**Section 2: ELECTRICAL INSTALLATION**

- c. If the customer-supplied Seawater Pump is not rated for the applied AC input voltage, the CABLE 5 output may be used to switch a customer-supplied relay.
  - i. Locate CABLE 5 for AC power output to the Seawater Pump from the Drive Box at the middle of three cable glands as shown in Figure 2.
  - ii. The recommended wiring is shown in Figure 6. Refer to Figure 4 for Cable 5 wire connections.



**FIGURE 6 – RECOMMENDED WIRING FOR SEAWATER PUMPS NOT MATCHING INPUT AC VOLTAGE**

- d. If CABLE 5 is not used, bundle cable and secure to forward brace or other area nearby which will not come in contact with moving parts during Seakeeper operation. Do NOT cut CABLE 5 as it contains live voltage when Seakeeper is in operation. Seakeeper ships with CABLE 5 permanently sealed at end of cable with protective cap in the event it is not used. Do NOT remove CABLE 5 from Drive Box as moisture will be free to enter box through open cable gland and corrode internal electronic components.



**Cable 5 contains live voltage when Seakeeper is in operation. Do NOT cut Cable 5. Do not remove Cable 5 from Drive Box.**

#### 4. 12 VDC POWER SOURCE REQUIREMENTS

- a. 12 VDC, 15 Amps.
- b. A separate breaker should be used for each Seakeeper.

**Section 2: ELECTRICAL INSTALLATION****5. SEAKEEPER DC POWER CONNECTION INSTRUCTIONS**

**Reversing polarity on the DC power input to the Seakeeper can result in damaging the electronics in the control system.**

- a. 12 VDC, 15 Amps. 2 x 12AWG (3 x 4mm<sup>2</sup> CSA) customer supplied.
  - i. Install Seakeeper provided DC Power Input Cable, P/N: 20248 as CABLE 1.
    1. Route CABLE 1 to DC Power Distribution Panel.
    2. Terminate RED conductor to +12 VDC. Terminate BLACK conductor to 12V Rtn or Zero VDC.
  - ii. Before connecting CABLE 1 to Seakeeper, check for proper voltage and polarity with a DC multimeter using Figure 7 below.

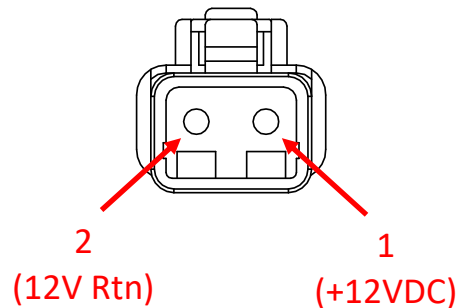

FIGURE 7 – DC POWER INPUT CONNECTOR  
CONTACT ASSIGNMENTS (front)

- iii. Connect CABLE 1 to 12VDC input receptacle on Seakeeper.



**When energizing DC power the first time, if Display does not power up immediately then disconnect and inspect connector polarity.**

**Section 2: ELECTRICAL INSTALLATION**

## 2.3 Electrical Equipment Ground Connections

### 1. SEAKEEPER TO VESSEL GROUND CONNECTION INSTRUCTIONS

- a. Connect the Seakeeper foundation to vessel ground.
  - i. Install CABLE 6 (4AWG or 22.0mm<sup>2</sup>, Customer supplied) from the M6 brass ground stud on the Seakeeper rear brace to a suitable vessel ground.

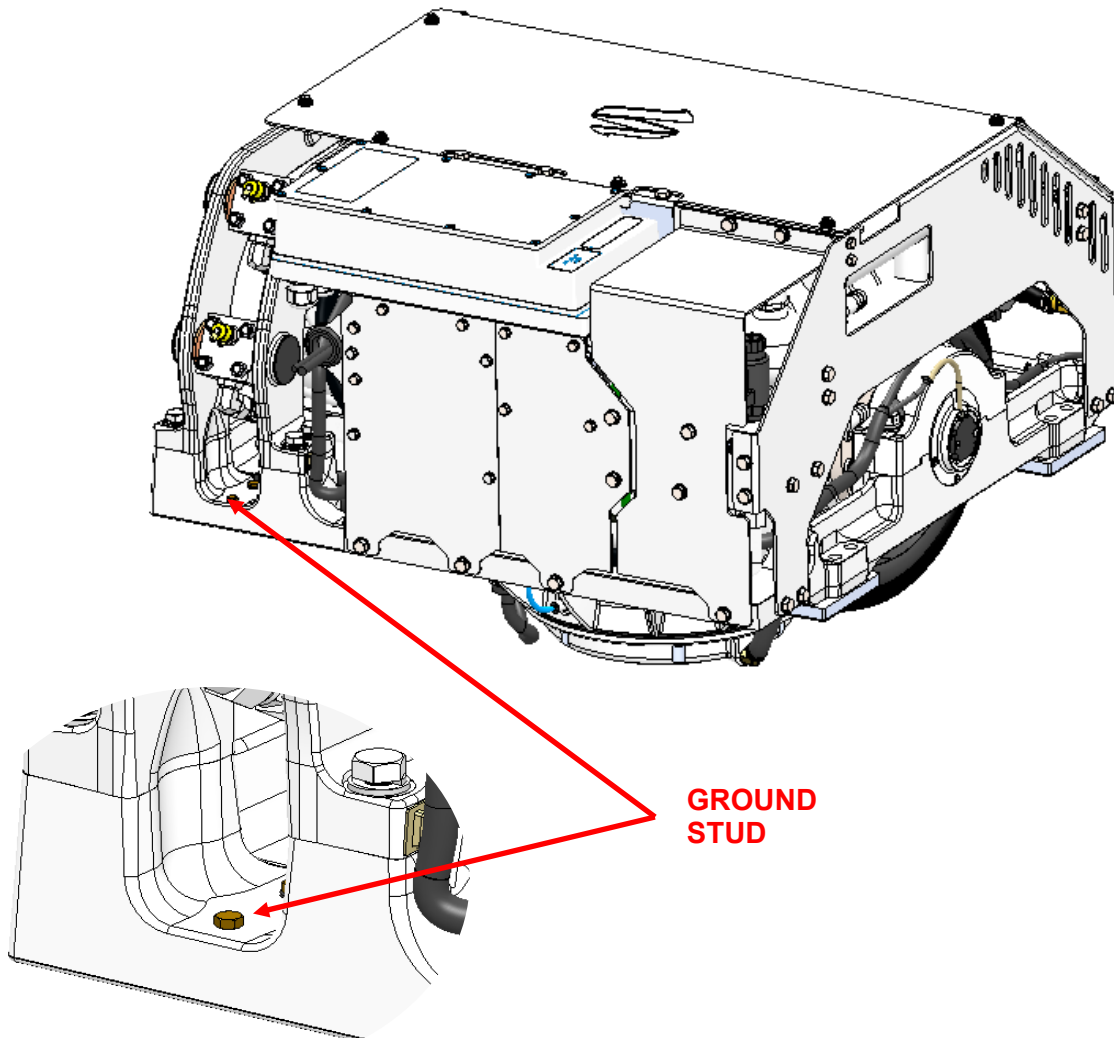

FIGURE 8 – SEAKEEPER GROUND STUD ON REAR OF FOUNDATION

**Section 2: ELECTRICAL INSTALLATION**

## 2.4 Operator Station

This section explains the connection between the Operator Station equipment and the Seakeeper Control Box.

### Reference Drawing

#### 90396 Seakeeper 6 Cable Block Diagram

#### 1. DETERMINE LOCATION OF OPERATOR STATION

- a. The desired location of the Operator Station must be determined with respect to the vessel arrangement.
- b. The operator display should be located on the bridge console.
- c. Figure 9 below shows the CANbus communications link for the Operator Station. The Terminator goes on one the far end of the Tee Adapter from the Seakeeper.

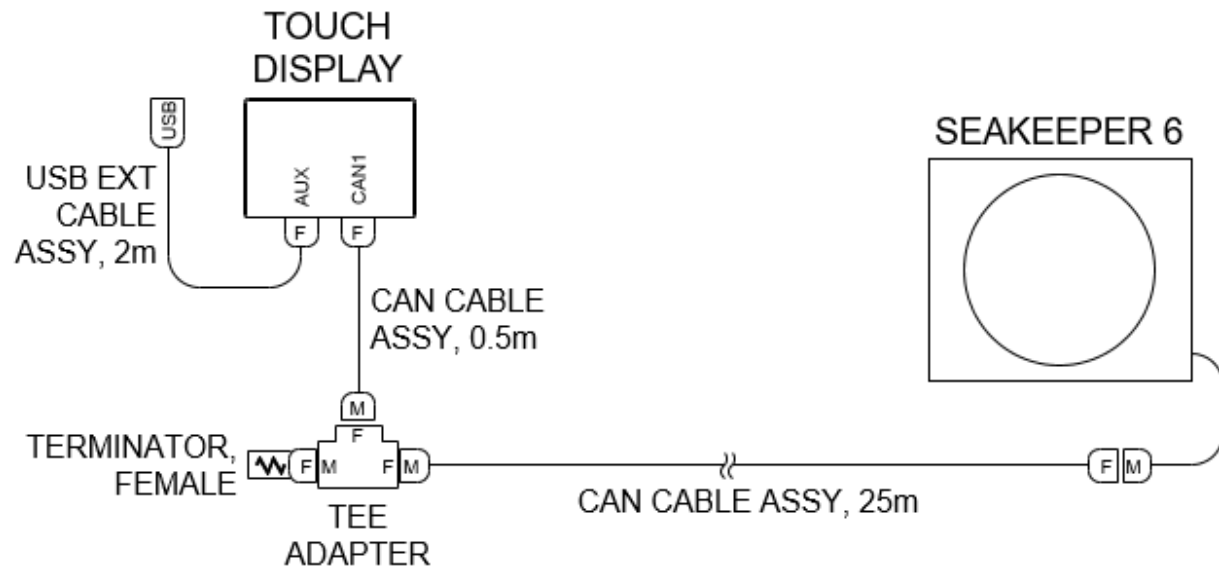

FIGURE 9 – SERIAL COMMUNICATIONS LINK FOR OPERATOR STATION

#### 2. ROUTE SERIAL COMMUNICATIONS CABLE

- a. The CAN Cable Assembly (30243, CABLE 3) is a 25 meter shielded cable and the largest connector is a molded plug with maximum outer diameter of .58 inch (14.8mm).
- b. CABLE 5 must be routed and installed in the vessel from the Seakeeper (female end) to the Tee Adapter (male end) at the Operator Station.

**Section 2: ELECTRICAL INSTALLATION****3. INSTALL OPERATOR STATION EQUIPMENT**

- a. The Operator Station equipment is installed at the selected location using Electrical Equipment Mounting Instructions in Section 2.1.

**4. CONNECT OPERATOR STATION EQUIPMENT**

- a. The Operator Station equipment is connected in accordance with the Cable Block Diagram, 90396.



Section 2: ELECTRICAL INSTALLATION

## 2.5 Display Installation Template

The following template is for mounting; before using this template, measure to ensure that the shown size is actual.

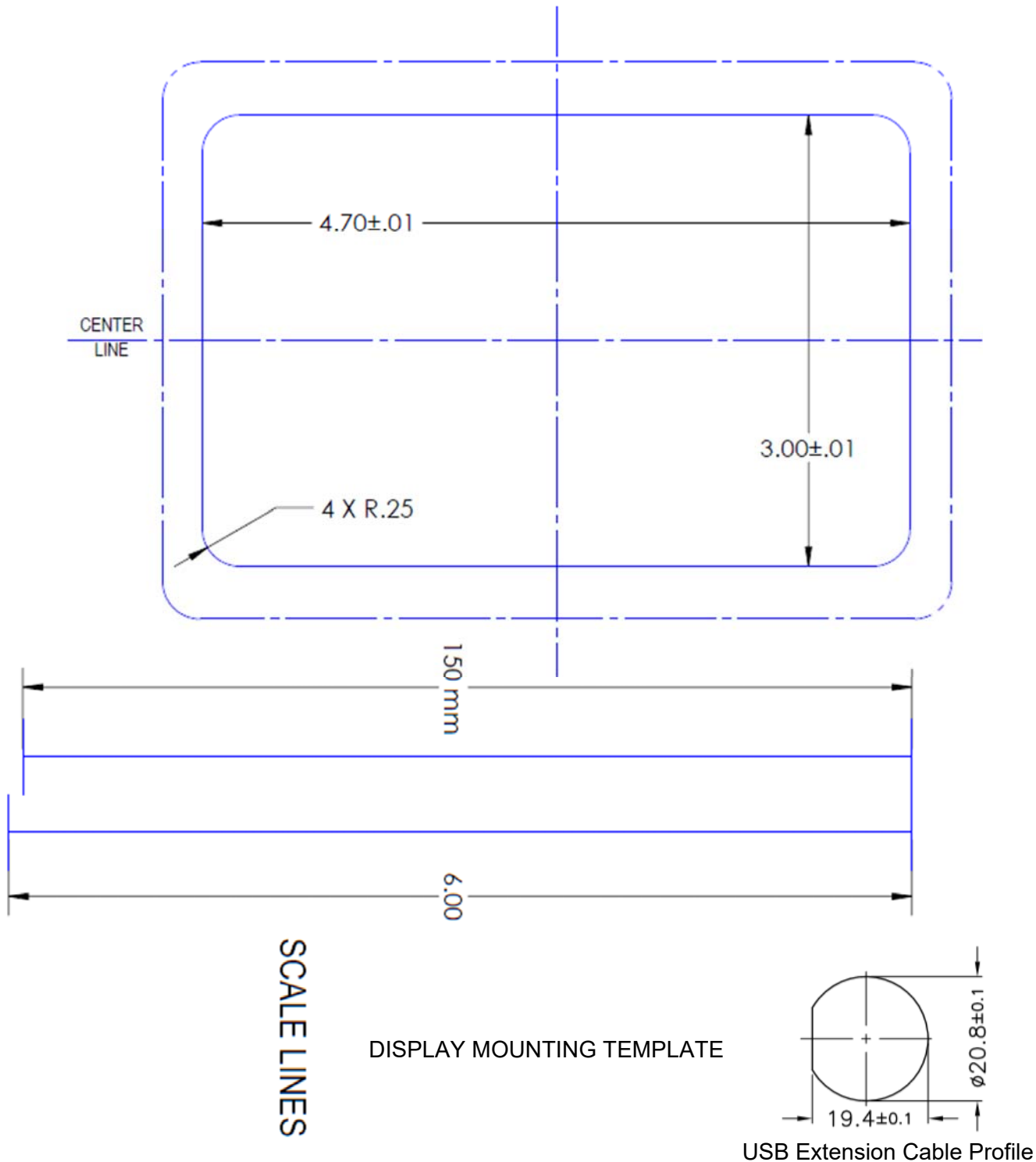

**Section 3: COOLING INSTALLATION**

### 3.0 Introduction

The Seakeeper 6 is shipped with the cooling circuit filled and ready for use. Only a quick confirmation of glycol level is required.

#### Reference Drawings

**90389** *Seakeeper 6 Hardware Scope of Supply*

**90396** *Seakeeper 6 Cable Block Diagram*

**90397** *Seakeeper 6 Cooling Water Schematic*

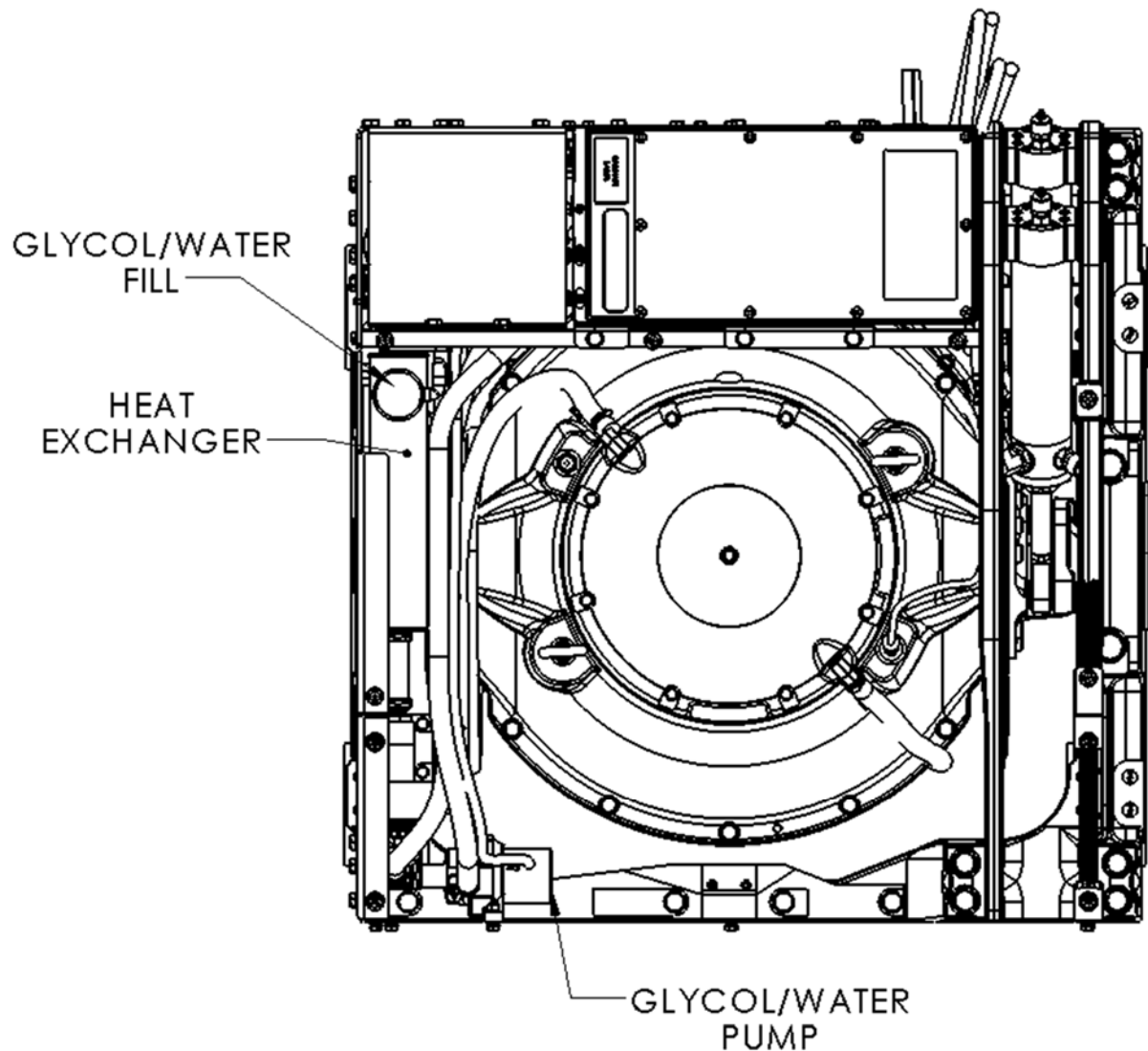
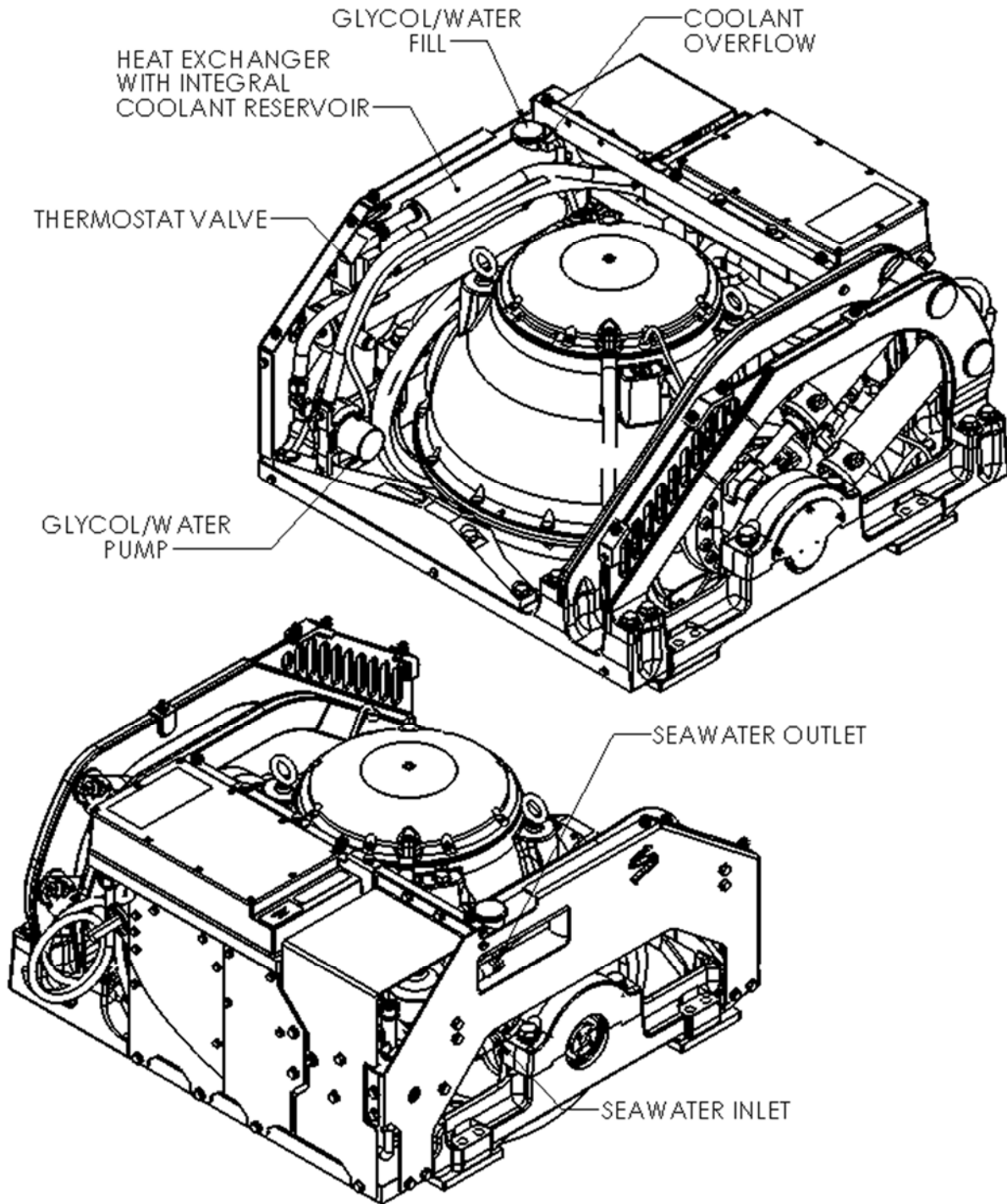

FIGURE 1 – SEAKEEPER 6

**Section 3: COOLING INSTALLATION**



**FIGURE 2 – SEAKEEPER 6 COOLING COMPONENTS**

**Section 3: COOLING INSTALLATION**

### 3.1 Precautions

- Installer is responsible for supplying a dedicated sea water pump and associated plumbing. Sea water connections on the heat exchanger mate with  $\frac{3}{4}$  inch (19 mm) hose.
- There is no need to disconnect hose from glycol pump except to replace the pump. In this case, provision will need to be made to catch draining glycol as plumbing is disconnected. Use caution to avoid breaking plastic hose connections on pump casing.
- An output is available from motor drive to power and automatically control seawater pump. This pump must operate on 110-230 VAC single phase and consume less than 5 amps. Pumps requiring other voltages or higher current can still be controlled by using this supply from motor drive to trigger an installer-supplied contactor but a separate source of power must be provided.
- Maximum sea water pressure in heat exchanger is 20 psi (1.4 bar)
- **Seawater flow requirement through heat exchanger is 4 GPM (15.1 LPM) minimum and 8 GPM (30.3 LPM) maximum under all operating conditions of the boat.** When sizing sea water pump, installer should factor in losses for raw water plumbing. In addition to initial operation at dock, new installations should be checked to be within the flow requirements while vessel is at speed. Flows higher than 8 GPM (30.3 LPM) could affect heat exchanger life.

### 3.2 Adding Coolant

- 1) Cooling system is filled to proper level when shipped, with a mixture of 50% ethylene glycol and 50% distilled water. Clear tube between thermostat housing and reservoir should be filled with green coolant mixture. If level has dropped, check for evidence of leaks at all connections before adding fluid as described below. If coolant is at the correct level, skip to sea water connection in section 3.3.

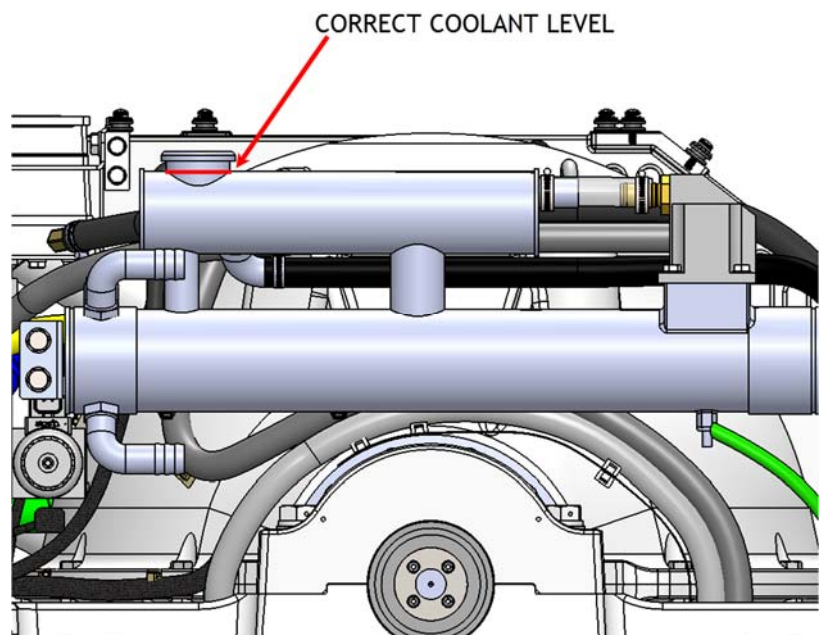

FIGURE 3 – SEAKEEPER 6 COOLANT LEVEL



**Section 3: COOLING INSTALLATION**

- 2) Mix 50% ethylene glycol with 50% distilled water in a clean container. Refer to Table 1 or glycol manufacturer's literature for freezing points.

Ethylene Glycol Solution (% by volume)		0	10	20	30	40	50	60
Temperature	(°F)	32	23	14	2	-13	-36	-70
	(°C)	0	-3	-8	-16	-25	-37	-55

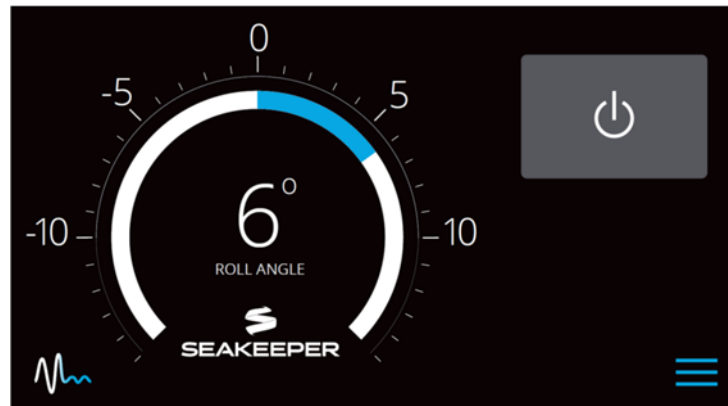
- 3) Remove pressure cap on top of reservoir. Pour mixture in until level reaches top of clear tube between thermostatic valve and reservoir as shown in Figure 3. Filling reservoir above this level will not cause any damage but coolant may be expelled from pressure relief port below cap due to normal thermal expansion of coolant.
- 4) Connect 12 V to controller.
- At the Display check for any ALARMS



- Press the POWER ON/OFF button 
- The flywheel will start to spin and the glycol pump will start.
- Recheck glycol level with fluid circulating in coolant circuit. Sight down inside reservoir and check that coolant level is above upper port on reservoir as shown in Figure 3. Replace cap.
- After several minutes of running, press POWER ON/OFF button  to turn power off to the flywheel and glycol pump. The glycol pump will stop and the flywheel will coast to a stop.

**Section 3: COOLING INSTALLATION**

5) The cooling system is self-purging. If small amounts of air are in the system, they will most likely be dislodged during the first sea trial. Re-check level after sea trial and add fluid if required.

### 3.3 Connecting Seawater to Heat Exchanger

- 1) Connect seawater from installer supplied pump to lower 3/4" (19 mm) hose barb on heat exchanger. Use the same practices as other below waterline seawater plumbing. Required flow rate is 4 GPM (16 LPM) minimum and 8 GPM (30.3 LPM) maximum.
- 2) Connect seawater discharge (upper hose barb) to overboard drain. Use the same practices as other below waterline seawater plumbing.
- 3) In addition to initial operation at dock, new installations should be checked for minimum 4 GPM (16 LPM) flow while vessel is at speed and when backing down. If no other method of confirming flow is available, discharge line may be temporarily diverted to a bucket. Flow is calculated from time to fill a known volume.
- 4) Inspect raw water plumbing after sea trial for any signs of leakage.
- 5) Heat exchanger contains removable end-caps to provide access for cleaning the tube bundle.

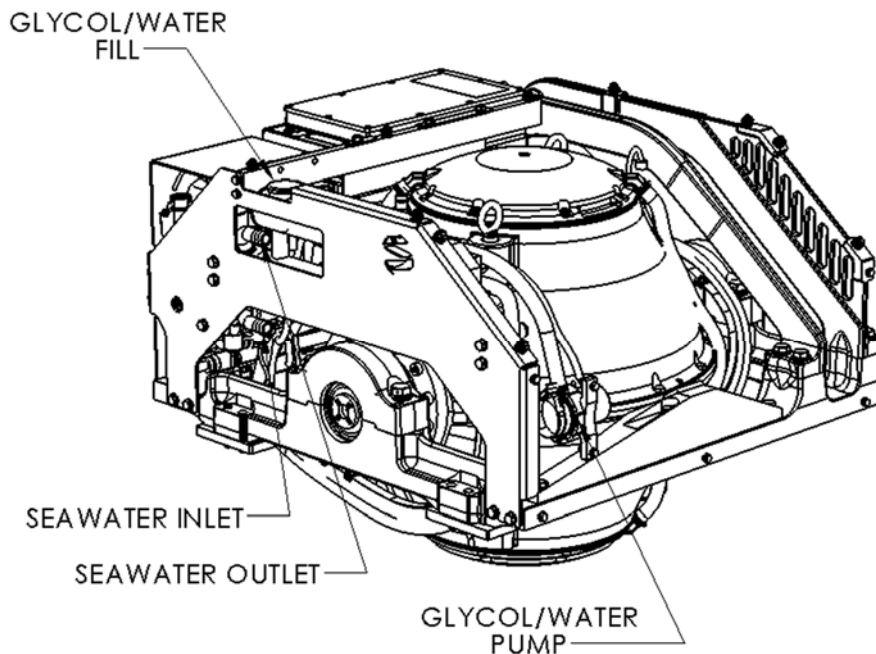

FIGURE 4 – SEAKEEPER 6 SEAWATER CONNECTIONS

**Section 4: STARTUP**

## 4.0 Introduction

This section describes the first startup of the Seakeeper.

Also reference Seakeeper Document # 90403, Seakeeper 6 Operation Manual.



- **Previous sections for mechanical, electrical and cooling installation must be completed before this startup sequence is initiated.**
- **Before continuing, covers must be installed and the area around the Seakeeper must be clear of personnel and equipment!**

## 4.1 Startup Instructions

- 1) Energize 12 VDC supply at the customer supplied electrical disconnect.
- 2) Supply 110-230 VAC to Motor Drive Box at customer supplied electrical disconnect.
- 3) If seawater pump for the Seakeeper is not supplied through cable from Motor Drive Box, turn on the boat's AC or DC dedicated circuit breaker that supplies power to the seawater pump.
- 4) With system powered up check the display for any ALARMS. If there are any ALARMS present they must be corrected first.
- 5) Press the Seakeeper ON/OFF Button on Display.  The progress bar will appear and indicate how soon the Seakeeper will be available for stabilization. When the Seakeeper is initialized and up to minimum operating speed the stabilize button



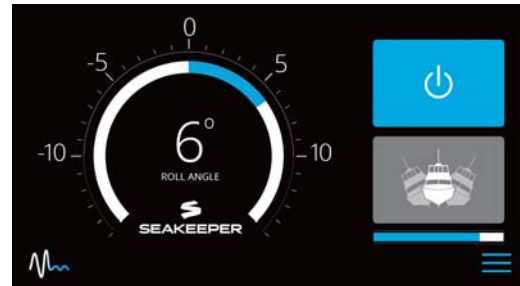
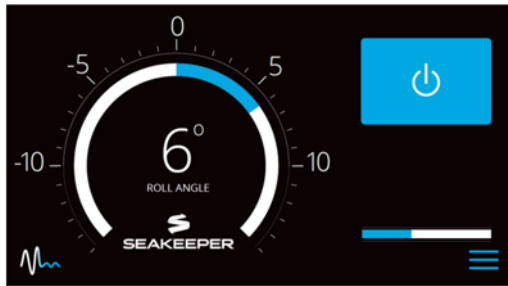

will appear. At this point, the Seakeeper is available for stabilization.

**Section 4: STARTUP**

- 6) The seawater pump will operate for two minutes after the ON/OFF button on the display was depressed. After that the seawater pump output is turned on and off based on the temperature of the Seakeeper. Confirm pump operation and flow rate, if practical. Required flow is 4 GPM (15 LPM) minimum and 8 GPM (30 LPM) maximum.
- 7) Verify that there are no ALARMS present. If an ALARM is present it will be displayed.
- 8) When the Seakeeper reaches its maximum operating speed where maximum stabilization is available, the progress bar will disappear and the Seakeeper is available

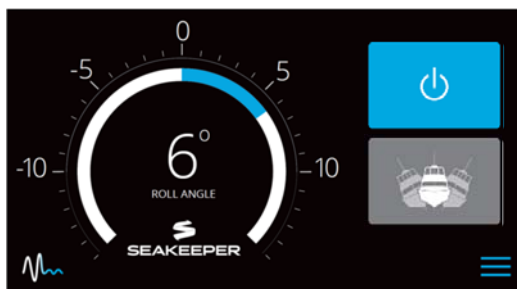
for maximum stabilization. Press the stabilize button.  The button will turn blue indicating that the Seakeeper is stabilizing the roll motion.



- 9) Verify that there are no alarms. If an ALARM is present it will be displayed.
- 10) Press the STABILIZE Button  to turn stabilization off. Then press the Seakeeper ON/OFF Button  to power the Seakeeper down.
- 11) During normal operation, the Seakeeper should be stopped when stabilization is no longer required. This maximizes long term life as it allows the Seakeeper to start the coast down cycle before cooling is shutoff. Once the vessel is secured in the slip and the crew has shut down the generator and engines, the AC and DC breakers that control the Seakeeper should be switched to the OFF position. The Seakeeper will continue to spool down to zero rpm. No cooling is required during this time. Note the Seakeeper 6



**Section 4: STARTUP**

will take 4+ hours to coast down to zero rpm from full speed. When the flywheel has stopped the service screen will indicate 0 RPM.



**Section 5: INSTALLATION CHECKLIST AND SUPPLIES**

**Please Complete Checklist and E-mail to [customerservice@seakeeper.com](mailto:customerservice@seakeeper.com)  
or telefax to +1.410.326.1199**

## **5.0 Installation Checklist**

### Mechanical Checklist (reference Installation Manual Section 1)

- Seakeeper Foundation Installed in Hull**
- Foundation bolts torqued to specification**

### Electrical Checklist (reference Seakeeper Drawing 90396 & Installation Manual Section 2)

#### **Mount Components**

- Display (near helm)**

#### **Connect Customer Supplied Cables**

- Cable 6 (customer supplied) – Install lugs on both ends of customer supplied 10AWG ground cable**
- Connect one end of Cable 6 to nearest vessel ground and other end to Seakeeper rear brace**

#### **Connect Seakeeper Supplied Cables**

- Cable 1 (Seakeeper supplied)– Connect other end of Cable 1 to 12 VDC power at customer supplied connection box or directly to circuit breaker**
- Plug connector of Cable 1 into mating connector on Seakeeper wire harness**
- Cable 2 (Seakeeper supplied)– Connect Cable 2 from Drive Box to 110-230 VAC single phase at customer supplied connection box or directly to circuit breaker**
- Cable 5 (Seakeeper supplied)– Connect Cable 5 from Drive Box to customer supplied 110-230 VAC seawater pump**
- Cable 3 (Seakeeper supplied)– Connect female end of CAN communications Cable 3 to mating connector on Seakeeper wire harness**

**Section 5: INSTALLATION CHECKLIST AND SUPPLIES**

- Route CAN communications Cable 3 from Seakeeper to helm (male end goes to helm)
- Connect male end of CAN communications Cable 3 at helm to CAN Tee Adapter
- Connect Display and Seakeeper supplied Cable 4 to CAN Tee Adapter with CAN Terminator

Cooling Checklist (reference Installation Manual Section 3)

- Verify coolant level in heat exchanger coolant reservoir.
- Connect sea water hoses / open sea cocks to heat exchanger and test sea water pump.
- Verify 4 GPM (15 LPM) minimum and 8 GPM (30 LPM) maximum sea water flow through heat exchanger under all operating conditions of the boat.

Startup Checklist (reference Installation Manual Section 4 and Operation Manual Section 2)

- Remove lifting bolts and install cover panels
- Turn on 12 VDC circuit breaker
- Turn on 110-230 VAC circuit breaker
- Verify display works and no alarms are present
- Follow instructions in Section 4.1 of Installation Manual to turn on the SEAKEEPER
- Verify sea water pump turns on when the SEAKEEPER is turned ON
- Verify that no ALARMS are present
- Follow instruction in Section 4.1 of Installation Manual to turn off the Seakeeper
- AC & DC power and sea water pump may be turned off after the SEAKEEPER is turned off by placing the SEAKEEPER in LOCK mode and turning the SEAKEEPER off
- Seakeeper takes 4 or more hours to coast down to zero rpm from full speed

**Section 5: INSTALLATION CHECKLIST AND SUPPLIES**

## 5.1 Required Supplies needed for Seakeeper Installation (not supplied with Seakeeper)

Item	Description	Qty	Installation Manual Reference Section	Other Reference	System
1	Adhesive and cleaning supplies for bonding to hull		1		Mechanical
2	Soundproofing Considerations		1		Mechanical
3	Spreader bar for lifting Seakeeper		1		Mechanical
4	Hose clamps for seawater plumbing to 3/4" (19 mm) hose barb (2 per hose barb)	4	3		Cooling
5	Circuit Breaker, AC, 2-Pole, (25 Amp to be used with 110-115 VAC, 20 Amp to be used with 208-230 VAC)	1	2.2.2	Dwg 90396	Electrical
6	Circuit Breaker, AC, 2-Pole, 5 Amp	1	2.2.3	Dwg 90396	Electrical
7	Circuit Breaker, DC, 1-Pole, 15 Amp	1	2.2.4-5	Dwg 90396	Electrical
8	M6 terminal lug for grounding Seakeeper at rear brace	1	2.3.1		Electrical
9	Cable, 10AWG, for grounding Seakeeper at rear brace to vessel ground (used with item 6)	AR	2.3.1	Dwg 90396	Electrical
10	Sea water pump, 110-230V AC	1	2.2.3		Electrical
11	Relay for sea water pump control (Not required if using Seakeeper output 110-230V AC pump)	1	2.2.3		Electrical

AR = As Required

Dwg = Drawing

**Section 5: INSTALLATION CHECKLIST AND SUPPLIES****List of common tools that may be required for installation**

<b>Item</b>	<b>Description</b>	<b>Use</b>
1	Wire cutter	DC Power, AC Power cables
2	Wire stripper	DC Power, AC Power cables
3	13mm Socket Wrench	Cover Panels
4	Phillips head screwdriver, 5/64 inch	Cover Panels
5	Slot screwdriver, 5/64 inch	Field assembly connectors
6	1/4 inch nutdriver	Hose clamps
7	Terminal or quick disconnect crimper	Power cables
8	Utility knife	Scoring cable jackets
9	10mm Socket Wrench	Ground Stud