

SEAKEEPER MOTOR LEAD TESTING - 124



PRODUCT ALL SEAKEEPER MODELS

PURPOSE

This procedure provides guidance in performing the phase-to-phase resistance and motor potting (insulation) testing on all Seakeeper flywheel motors.

BACKGROUND

As in any motor, Seakeeper flywheel motor windings and cable insulation are susceptible to breakdown. Failure in a phase's insulation will cause slowing of the flywheel motor. Megohm testing is needed to accurately determine the need to replace a sphere. A time-resistance megohm test is provided because an instantaneous megohm reading does not ensure accuracy without historical values.

In factory testing, it has been found that arcing occurs when megohm testing is conducted in an enclosure at atmospheric pressure; an enclosure sphere vacuum ensures minimized arcing damage to motor windings.

Seakeeper recommends a Time-Resistance megohm test because it is independent of temperature and can give conclusive evidence without recorded past tests. This method accounts for the absorption effect of good insulation compared to compromised insulation. Good insulation will show a continual rise in resistance over time. This rise is caused by the absorption of voltage in the stator windings. Degraded winding insulation will have a higher leakage current to keep resistance constant.

The time-resistance method is independent of meter quality or winding types or sizes between models. It provides a clearer understanding of insulation breakdown even when an instantaneous reading shows a high resistance.

A ratio between the 30-second and 60-second readings will provide a ratio helpful in evaluating the insulation breakdown in a motor. When customer time and expense are at stake, Seakeeper desires to eliminate all doubt when determining whether a sphere replacement is necessary.

TOOLS & SUPPLIES REQUIRED

- Megohm meter capable of maintaining a test voltage (1000 V for AC models / 500 V for Seakeeper 2 through 4 models / 250 V for Seakeeper 1) for one minute.
- Digital Multimeter
- Phillips #2 screwdriver [for AC motor drive box (MDB)]
- Torque wrench (inch-pounds/Nm)
- Phillips bit for torque wrench (for AC MDB)
- Sockets and ratchet wrench
- SAE and Metric combination wrench sets
- T15 Torx® key (for DC MDB cover screws)

SEAKEEPER MOTOR LEAD TESTING - 124



PRODUCT ALL SEAKEEPER MODELS

REFERENCE:

[SWI-129, Seakeeper Vacuum Gauge Operation](#)

PRECAUTIONS

1. PERSONNEL INJURY MAY RESULT if Seakeeper is NOT locked and at zero RPM before removing covers or accessing unit for service.
2. PERSONNEL INJURY MAY RESULT if attempting to perform maintenance on Seakeeper without removing flywheel motor power and applying lockouts due to remote start capabilities.
3. DAMAGE TO MOTOR WINDINGS MAY OCCUR if megohm testing between phases; Megohm tests are conducted from a phase lead to ground.
4. DAMAGE TO MOTOR WINDINGS MAY OCCUR if megohm testing is conducted on enclosure with no vacuum due to arcing.

NOTES

1. Improper test results may occur if leads are not electrically isolated (in contact with metallic surfaces) during testing.
2. Seakeeper Product Support Team can better assist if all data and actions taken are recorded during testing and that information is immediately shared with Seakeeper.
3. For AC-powered models, use [Section 1](#).
For DC-powered models, use [Section 2](#).

SEAKEEPER MOTOR LEAD TESTING - 124



PRODUCT ALL SEAKEEPER MODELS

PROCEDURE

[Link to Testing DC-Powered Models](#)

SECTION 1: TESTING AC-POWERED MODELS

1. **RECORD** all data taken during this procedure for submittal in communication.
2. **ENSURE** enclosure sphere of Seakeeper tested has vacuum (less than 100 torr):
 - a. **IF** enclosure has no vacuum sensor,
THEN DETERMINE enclosure pressure by [SWI-129, Vacuum Gauge Operation](#).

 <p>WARNING!</p> <p>PERSONNEL SHOCK HAZARD EXISTS WHEN FLYWHEEL ROTATING OR POWER ALIGNED TO SEAKEEPER.</p>

3. **TURN OFF** AC power breaker to Seakeeper.
4. **ENSURE** DC power aligned for brake override.
5. **ENSURE** flywheel RPM is zero.
6. **REMOVE** MDB cover.
7. **STORE** motor drive cover's ten M4 screws in safe place for re-use.

SEAKEEPER MOTOR LEAD TESTING - 124



PRODUCT ALL SEAKEEPER MODELS

NOTE:

Some Seakeeper models have a motor ground and a shield ground at motor terminal.

8. **REMOVE** three phase leads, shield ground, and motor ground cable from "MOTOR" terminal.
 - a. **IF** motor leads are not color-coded, **THEN IDENTIFY** each lead with a piece of tape as to location found (WH, RD, or BK).

Shield ground (16 AWG)

Motor ground (12 AWG)

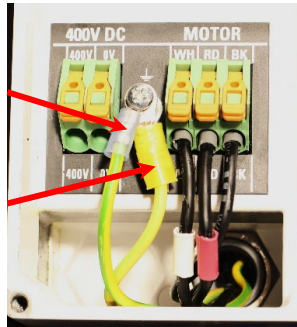

Figure 1: Motor with shield and motor ground



Figure 2: Motor with just shield ground

NOTE:

Electrical isolation of cables can be achieved by placing electrician's tape over cable ends.

9. **ENSURE** motor leads are electrically isolated from each other and MDB frame.
10. **IF** Seakeeper has an enclosure ground near the equator, **THEN REMOVE** enclosure ground cable on enclosure near equator (Fig.3).
11. **ENSURE** enclosure ground cable electrically isolated from enclosure.
12. **ACTIVATE** brake override.
13. **PERFORM** thorough visual inspection of motor power cable from motor drive to feed-through on enclosure.
 - a. **IF** any cable or feed-through damage found, **THEN:**
 - i. **PHOTOGRAPH** damage.
 - ii. **SUBMIT** photos with data from tests.

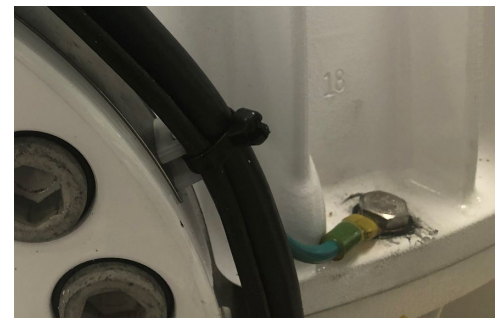

Figure 3: Seakeeper enclosure ground lug on early AC model.

SEAKEEPER MOTOR LEAD TESTING - 124



PRODUCT ALL SEAKEEPER MODELS

NOTE:

Intermittent opens or shorts may not be seen if cable is not manipulated to duplicate movement of precession.

14. With multimeter in resistance mode, **MEASURE** resistance between each motor phase wire end crimp to one decimal place (Fig. 4).
 - a. **RECORD** measurements.

Resistance (Ω) Between Phases	
Black (W/L3) to White (U/L1)	
White (U/L1) to Red (V/L2)	
Black (W/L3) to Red (V/L2)	

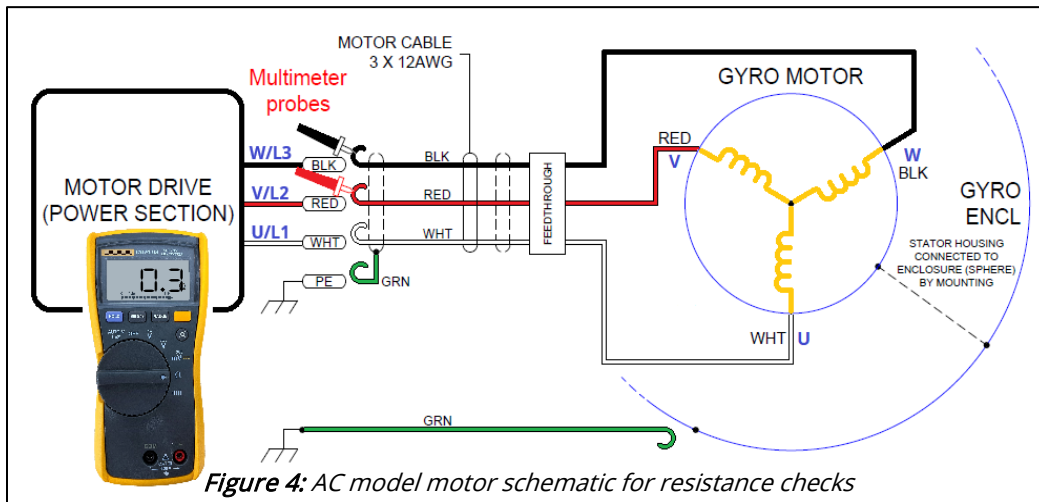

15. **PRECESS** enclosure sphere fully forward, backwards, and return to upright position.
16. **REPEAT** resistance measurements to confirm initial readings.

SEAKEEPER MOTOR LEAD TESTING - 124



PRODUCT ALL SEAKEEPER MODELS

CAUTION:

DAMAGE TO MOTOR MAY OCCUR IF TESTED
PHASE TO PHASE



WARNING!

SHOCK HAZARD EXISTS WITH CURRENT
& HIGH VOLTAGE TO MOTOR CABLE LEADS

17. **PERFORM** megohm testing on each phase, one at a time, as follows:

- a. **ATTACH** black megohm test lead to one of following:
 - enclosure ground lug (near equator)
 - Enclosure at eyebolt or vacuum service port
- b. **ATTACH** red megohm test lead to phase in test.

CAUTION:

MOTOR DAMAGE MAY OCCUR IF TESTED AT A HIGHER VOLTAGE THAN SPECIFIED.

c. **PLACE** megohmmeter on scale of **1000V**.

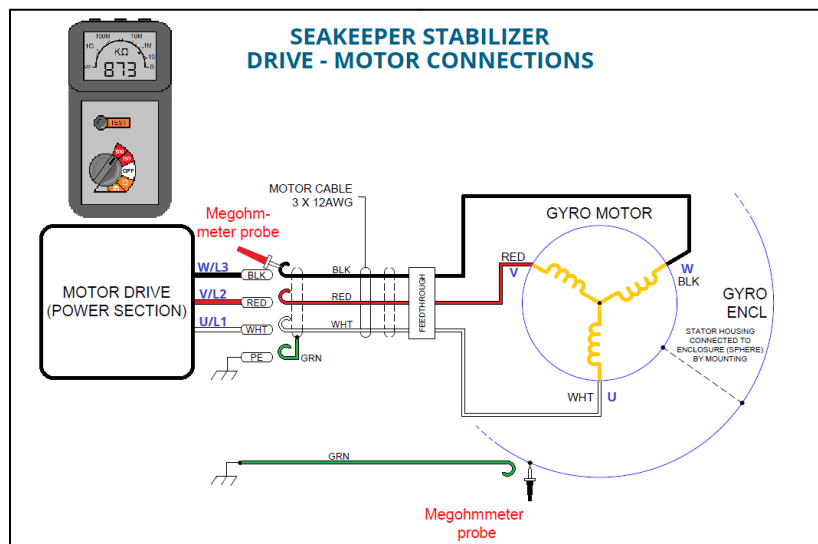

Figure 5: AC model motor schematic for phase insulation checks

SEAKEEPER MOTOR LEAD TESTING - 124



PRODUCT ALL SEAKEEPER MODELS

18. With each phase, one at a time, **PRESS AND HOLD** megohmmeter's test button for 60 seconds.

a. **RECORD** readings and units (e.g., kΩ, MΩ, or GΩ) at 30 seconds and 60 seconds.

White (U/L1): 30 Seconds: _____ **60 Seconds:** _____

Red (V/L2): 30 Seconds: _____ **60 Seconds:** _____

Black (W/L3): 30 Seconds: _____ **60 Seconds:** _____

19. **MANUALLY PRECESS** sphere enclosure full travel, forward and back.

20. **REPEAT** test momentarily to verify same initial resistance (it is NOT necessary to repeat 60 second test).

21. **CALCULATE** following:

a. For each megohm test result, **DIVIDE** 60 second reading by 30 second reading to determine ratio.

For example, say at 30 seconds one reads resistance of 110 Mohms. At 60 seconds, they read 600 Mohms. Determine ratio of 60 second reading divided by 30 second reading as follows:

$$\underline{600 \text{ Mohms}} \div \underline{110 \text{ Mohms}} = \underline{5.45} \text{ is ratio}$$

WHITE (U / L1): (60 sec) _____ **÷ (30 sec)** _____ = _____

RED (V / L2): (60 sec) _____ **÷ (30 sec)** _____ = _____

BLACK (W / L3): (60 sec) _____ **÷ (30 sec)** _____ = _____

SEAKEEPER MOTOR LEAD TESTING - 124



PRODUCT ALL SEAKEEPER MODELS

22. For minimum of 60 seconds, **MEASURE** megohm resistance of each phase to shield ground of motor drive cable at 1000V.

Circle one

WHITE (U/L1): _____ (**MΩ** **GΩ**),

RED (V/L2): _____ (**MΩ** **GΩ**),

BLACK (W/L3): _____ (**MΩ** **GΩ**)

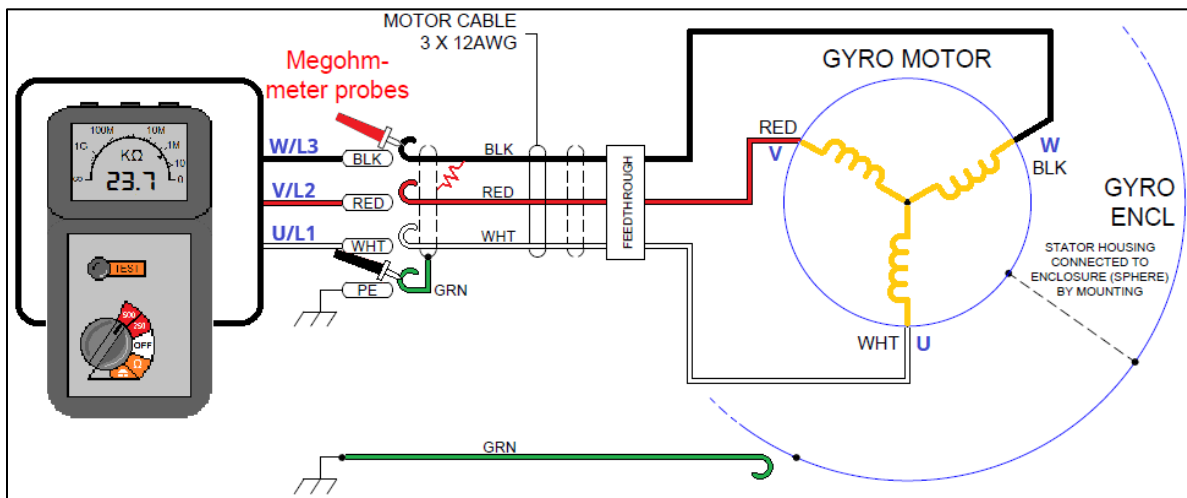
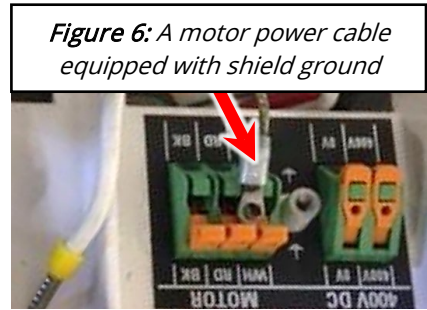

Figure 7: Motor schematic with shield ground

SEAKEEPER MOTOR LEAD TESTING - 124



PRODUCT ALL SEAKEEPER MODELS

- 23. **DOCUMENT** any physical damage of motor power cable or leads with photograph.
- 24. **CONTACT** Seakeeper Product Support Team with ALL data taken for evaluation while still onsite. (Email support@seakeeper.com or emeasupport@seakeeper.com after hours)
 - a. Americas Telephone: +1 (410) 326-1590
 - b. EMEA Telephone: +39 0185 1897071



WARNING!

SHOCK HAZARD EXISTS DUE TO CAPACITANCE FROM MEGOHM TESTING

- 25. **IF** model has an enclosure ground cable, **THEN**, while holding ground wire insulation, **TORQUE** enclosure ground cable onto enclosure ground lug per table below.

MODEL	TORQUE SPECIFICATION	NOTES
Seakeeper 5 (EM)	120 in-lbs	Use only internal tooth lock washer, 5/16" screws size. P/N: 60276.  Apply Loctite 243 to bolt threads.
Seakeeper 6/5	200 in-lbs	Use only internal tooth lock washer, 5/16" screws size. P/N: 60276
Seakeeper 9/7HD	120 in-lbs	No washer under bolt head. Use conductive paste under cable lug.
Seakeeper 16/12HD & 18	200 in-lbs	
Seakeeper 26/20HD		
Seakeeper 35/30HD/40		

- 26. **RE-ATTACH** all motor cable leads to their respective terminal.
- 27. **ENSURE** other leads within Motor Drive are attached properly.
- 28. **INSTALL** MDB cover with ten M4 screws.
- 29. **TORQUE** ten M4 screws of cover to **19 in-lbs (2.2 Nm)** to prevent moisture intrusion.

******* END *******

SEAKEEPER MOTOR LEAD TESTING - 124

PRODUCT ALL SEAKEEPER MODELS

SECTION 2: TESTING DC-POWERED MODELS

1. **RECORD** all data taken during this procedure for submittal in communication.
2. **ENSURE** enclosure sphere of Seakeeper tested has vacuum (less than 100 torr):
 - a. **IF** enclosure has no vacuum sensor,
THEN DETERMINE enclosure pressure by [SWI-129, Vacuum Gauge Operation](#).

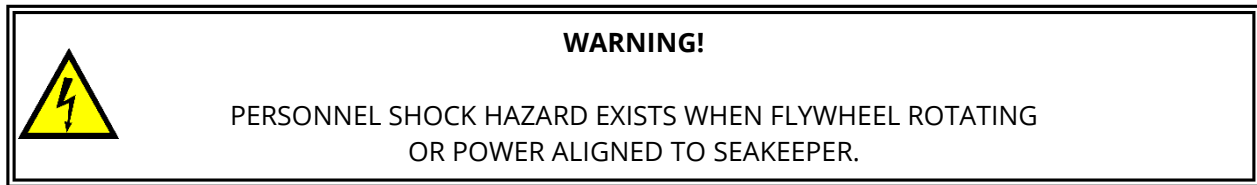

3. **ENSURE** low-current DC power aligned for brake override. **[N/A on Seakeeper 1]**
4. **DISCONNECT** motor power cable leads as follows:
 - a. For Seakeeper 2, 3, and 4:
 - i. **REMOVE** motor terminal cover with T15 Torx® key (Fig. 8).
 - ii. **REMOVE** cable clamp with T15 Torx® key (Fig. 8).

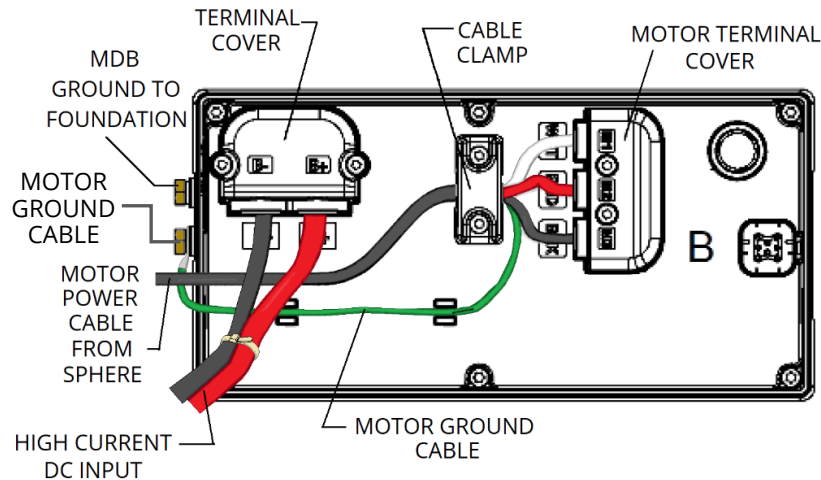

Figure 8: Components of a DC motor drive

- iii. **REMOVE** motor ground cable from MDB side lug with 10 mm socket.
- iv. **REMOVE** motor leads from motor terminal with 8 mm socket.
- v. **ENSURE** leads are electrically isolated (NOT in contact with other metal).

SEAKEEPER MOTOR LEAD TESTING - 124



PRODUCT ALL SEAKEEPER MODELS

Section 2, Step 4 continued

- b. For Seakeeper 1:
 - i. **REMOVE** clear gel coating of motor lead lugs.
 - ii. **IF** no label attached to each motor lead, **THEN LABEL** each cable as U, V, or W based on their connection post designation (Fig. 9).
 - iii. **REMOVE** motor leads from Curtis drive with 10 mm socket.
 - iv. **REMOVE** green/yellow motor ground cable with 10 mm socket.
 - v. **ENSURE** all leads are NOT in contact with each other or metal frame.

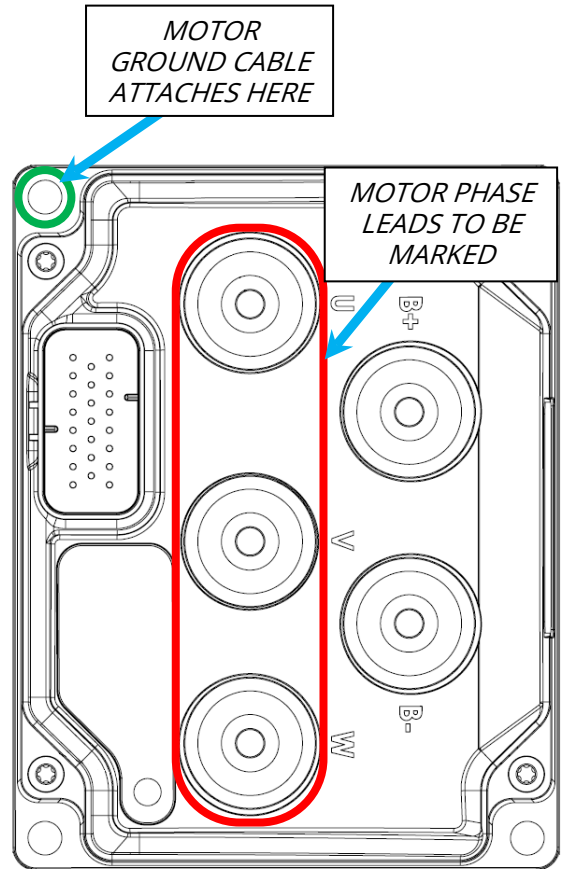

Figure 9: Components of a Curtis drive

- 5. **ACTIVATE** brake override.
- 6. **PERFORM** visual inspection of motor power cable from motor drive to feed-through on enclosure.
 - a. **IF** any cable or feed-through damage found, **THEN:**
 - i. **PHOTOGRAPH** damage.
 - ii. **SUBMIT** photos with data from tests to Seakeeper Product Ssupport Team.

SEAKEEPER MOTOR LEAD TESTING - 124



PRODUCT ALL SEAKEEPER MODELS

NOTE:

Intermittent opens or shorts may not be seen if cable is not manipulated to duplicate movement of precession.

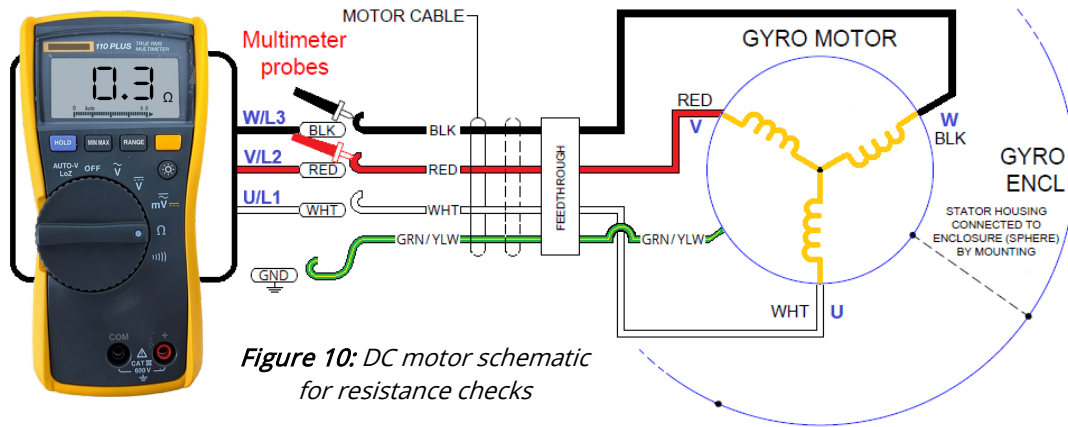

Figure 10: DC motor schematic for resistance checks

7. With a multimeter in resistance mode, **MEASURE** resistance between each phase wire end crimp to one decimal point per Figure 10.
 - a. **RECORD** measurements.

Resistance (Ω) Between Phases	
Black (W/L3) to White (U/L1)	
White (U/L1) to Red (V/L2)	
Black (W/L3) to Red (V/L2)	

8. **MANUALLY PRECESS** sphere enclosure full forward and aft.
9. **REPEAT** resistance measurements.

SEAKEEPER MOTOR LEAD TESTING - 124



PRODUCT ALL SEAKEEPER MODELS

10. **PERFORM** megohm testing on each phase per Figure 11, one at a time, as follows:
 - a. **ENSURE** any motor phase leads NOT in test is electrically isolated (NOT touching metal).
 - b. **ATTACH** black megohm test lead to motor ground lead.
 - c. **ATTACH** red megohm test lead to phase in test.

CAUTION:

MOTOR DAMAGE MAY OCCUR IF TESTED AT A HIGHER VOLTAGE THAN SPECIFIED.

- d. **PLACE** megohmmeter on correct scale:
 - i. For Seakeeper 2, 3, and 4: **500 V**
 - ii. For Seakeeper 1: **250V**

Seakeeper 1, 2, 3, and 4

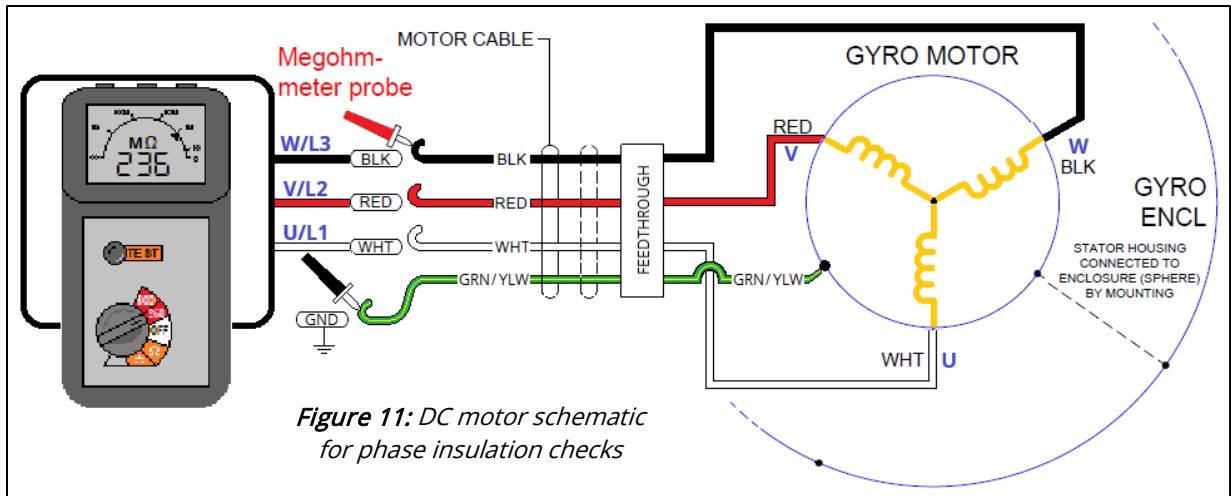

SEAKEEPER MOTOR LEAD TESTING - 124



PRODUCT ALL SEAKEEPER MODELS

CAUTION:
DAMAGE TO MOTOR MAY OCCUR IF TESTED
PHASE TO PHASE

WARNING!
SHOCK HAZARD EXISTS WITH CURRENT
& HIGH VOLTAGE TO MOTOR CABLE LEADS



11. **PRESS AND HOLD** megohmmeter's test button for 60 seconds.
 - a. **RECORD** resistance readings and units (e.g., kΩ, MΩ, or GΩ) of each lead at 30 seconds and 60 seconds.

White (U/L1): 30 Seconds: _____	60 Seconds: _____
Red (V/L2): 30 Seconds: _____	60 Seconds: _____
Black (W/L3): 30 Seconds: _____	60 Seconds: _____
12. **MANUALLY PRECESS** sphere enclosure full forward and aft.
13. **REPEAT** test momentarily to verify same initial resistance (it is NOT necessary to repeat 60 second test).

SEAKEEPER MOTOR LEAD TESTING - 124



PRODUCT ALL SEAKEEPER MODELS

14. **CALCULATE** following:

- a. For each megohm test result, **DIVIDE** 60 second reading by 30 second reading to determine ratio.

For example, say at 30 seconds one reads resistance of 110 Mohms. At 60 seconds, they read 600 Mohms. Determine ratio of 60 second reading divided by 30 second reading as follows:

$$600 \text{ Mohms} \div 110 \text{ Mohms} = \mathbf{5.45} \text{ is ratio}$$

WHITE (U/L1): (60 sec) _____ ÷ (30 sec) _____ = _____

RED (V/L2): (60 sec) _____ ÷ (30 sec) _____ = _____

BLACK (W/L3): (60 sec) _____ ÷ (30 sec) _____ = _____

15. **DOCUMENT** any physical damage with photograph.
16. **CONTACT** Seakeeper Product Support Team with ALL data while still onsite if possible. (Email support@seakeeper.com or emeasupport@seakeeper.com after hours)
- Americas Telephone: +1 (410) 326-1590
 - EMEA Telephone: +39 0185 1897071
17. **RE-ATTACH** all motor leads and ground to their respective terminals at MDB/Curtis drive controller.

SEAKEEPER MOTOR LEAD TESTING - 124



PRODUCT ALL SEAKEEPER MODELS

18. **TORQUE** motor leads as follows:

- a. For Seakeeper 2, 3, and 4:
 - i. **TORQUE** motor terminal screws to **30 in-lbs (3.3 Nm)** with 8 mm socket.
 - ii. **TORQUE** motor ground screw to **40 in-lbs (4.5 Nm)** with 10 mm socket.

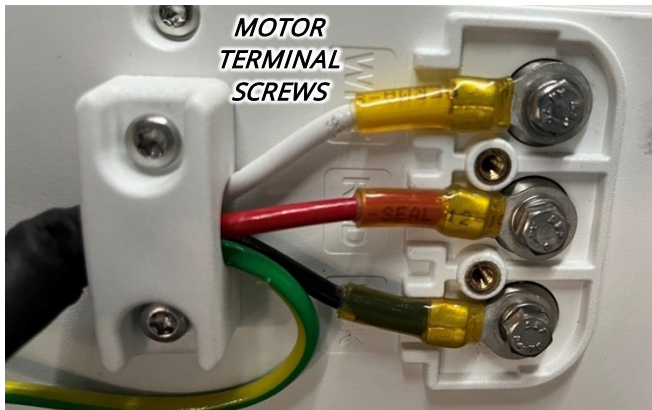

Figure 12: DC motor phase terminals



Figure 13: DC motor ground cable

- iii. **INSTALL** remaining terminal cover and cable clamp.
- b. For Seakeeper 1, **TORQUE** motor terminal screws to **90 in-lbs (10.2 Nm)** per Figure 14.

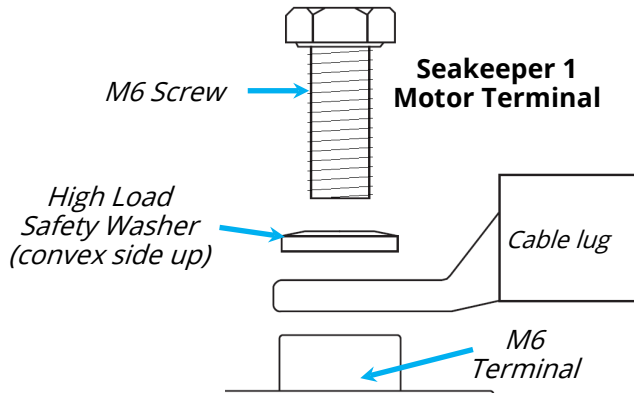

Figure 14: Curtis drive motor phase terminals

***** **END** *****

Revision	Description	Approval	Date
9	Added additional insulation identification markings (i.e., U/L1, V/L2, and W/L3)	A Patricio	17MAR2026
10	Moved time resistance explanation to Background. Rewrote steps for clarity. Added note for electrical isolation.	A Patricio	12MAY2026